

Operating Instructions

Robacta TC 1000
Robacta TC 1000 ext.

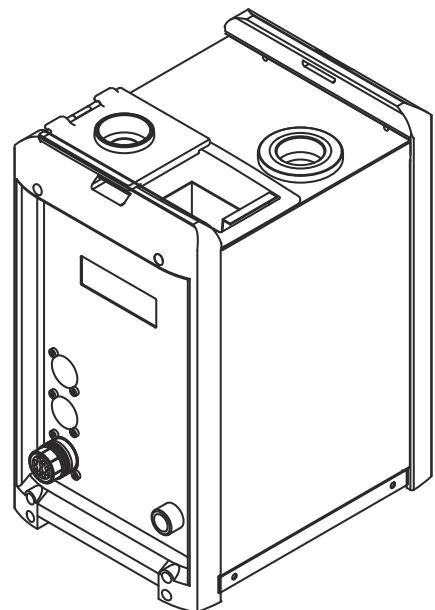

EN | Operating Instructions



Contents

Safety rules.....	6
Explanation of safety notices	6
General.....	6
Proper use	7
Environmental conditions.....	7
Obligations of the operator.....	7
Obligations of personnel.....	7
Specific hazards.....	8
Protecting yourself and others.....	8
Risks from mains current and operating current.....	9
EMC Device Classifications.....	10
EMC measures.....	10
Safety measures at the installation location and during transport.....	10
Safety measures in normal operation.....	11
Maintenance and repair.....	11
Safety inspection.....	12
Disposal.....	12
Safety symbols.....	12
Data protection	12
Copyright.....	12
General	15
General.....	17
Device concept.....	17
Application areas.....	18
Warning notices on the device.....	18
Parting agent types and their use.....	20
Functional principle	21
Functional principle	21
Scope of supply and options.....	23
General.....	23
Robacta TC 1000 scope of supply	23
Robacta TC 1000 options.....	23
Robacta TC 1000 ext. scope of supply.....	23
Robacta TC 1000 ext. options.....	23
Transport.....	24
Transport devices	24
Transport notices on the packaging.....	24
Controls, connections and mechanical components	25
Safety	27
Safety	27
Control panel.....	28
General.....	28
Control panel.....	28
Robacta TC 1000.....	30
Robacta TC 1000 connections and mechanical components	30
Base unit and cleaning unit P.....	32
Base unit and cleaning unit P.....	32
Base unit and cleaning unit S.....	34
Base unit and cleaning unit S.....	34
Standard I/O connecting plug (X1) pin assignment for robot control.....	36
General.....	36
Standard I/O connecting plug (X1) pin assignment.....	36
Installation and commissioning	39
Safety	41
Safety	41

Before commissioning	42
Operators, maintenance personnel.....	42
Setup regulations	42
Compressed air supply specifications.....	42
Mains connection.....	42
Bolting the Robacta TC 1000 to the underlying surface (foundation).....	44
Bolting the Robacta TC 1000 together with installation stand to the underlying surface (foundation).....	44
Screw the base unit and cleaning unit to the underlying surface (foundation) and connect them to each other.....	45
Installation instructions.....	45
Screw the base unit and cleaning unit P. to the underlying surface (foundation) and connect them to each other	45
Bolting the base unit and cleaning unit S. to the underlying surface (foundation) and connecting them to each other.....	46
Installing the wire cutter	48
Installing the wire cutter on the Robacta TC 1000	48
Fitting the wire cutter to cleaning unit S.....	48
Fitting the wire cutter to cleaning unit P.....	49
Maximum wire diameter.....	49
How the mechanically controlled wire cutter works.....	49
How the electrically-controlled wire cutter works	50
Filling the dipping bowl with parting agent.....	51
Filling the dipping bowl with parting agent.....	51
Installing and commissioning the parting agent nebuliser (only for Robacta TC 1000).....	52
Installing the parting agent nebuliser on the Robacta TC 1000	52
Starting up the parting agent nebuliser.....	53
Starting up the parting agent nebuliser V.....	54
Robacta TC 1000: Installing parting agent nebuliser V.....	54
Cleaning unit S.: Installing parting agent nebuliser V	54
Cleaning unit P.: Installing parting agent nebuliser V	55
Filling the "Robacta Reamer" parting agent container with parting agent.....	56
Connecting the 'Robacta Reamer' parting agent container (10 litres) to the cleaning device.....	57
Fitting and using the fill-level control sensor.....	59
General.....	59
Controls and indicators on the sensor	59
Installation adapter borehole dimensions.....	59
Fitting the fill-level control sensor.....	60
Calibrating the empty state	61
Calibrating the full state.....	61
Locking/unlocking the fill-level control sensor.....	62
Electrical connection.....	62
Starting up the cleaning device.....	63
General.....	63
Prerequisites for start-up.....	63
Welding torch cleaning position when using Robacta TC 1000 TwinCompact.....	63
Cleaning programme	65
Overview of program sequence with dipping bowl.....	65
Overview of program sequence with parting agent nebuliser	65
Overview of program sequence with parting agent nebuliser and dipping bowl.....	65
Cooling welding torch in the dipping bowl - detailed description.....	65
Cleaning the gas nozzle tip - detailed description	66
Cleaning the nozzle fitting - detailed description	66
Spraying parting agent - detailed description	67
Cleaning program sequence with dipping bowl.....	68
Cleaning program sequence with parting agent nebuliser.....	69
Troubleshooting, maintenance and disposal	71
Safety	73
Safety	73

Troubleshooting 75
 Troubleshooting 75
 Fault procedure for Robacta TC 1000 ext. 78
 Fault procedure..... 78
 Care, maintenance and disposal 79
 Before each start-up..... 79
 Daily 79
 Weekly 79
 Every 3 months..... 80
 Every 6 months 80
 Every 12 months 80
 Clean suction filter in parting agent container..... 80
 Disposal..... 81

Technical data 83

Technical data..... 85
 General..... 85
 Robacta TC 1000 / Robacta TC 1000 ext. (Base unit) / Robacta TC 1000 Twin / Robacta
 TC 1000 Twin Compact 85
 Cleaning unit S/P..... 85
 Robot control supply 86
 Digital inputs..... 86
 Digital outputs..... 86

Safety rules

Explanation of safety notices

DANGER!

Indicates immediate danger.

- ▶ If not avoided, death or serious injury will result.
-

WARNING!

Indicates a potentially hazardous situation.

- ▶ If not avoided, death or serious injury may result.
-

CAUTION!

Indicates a situation where damage or injury could occur.

- ▶ If not avoided, minor injury and/or damage to property may result.
-

NOTE!

Indicates a risk of flawed results and possible damage to the equipment.

General

The device is manufactured using state-of-the-art technology and according to recognised safety standards. If used incorrectly or misused, however, it can cause:

- injury or death to the operator or a third party,
 - damage to the device and other material assets belonging to the operating company,
 - inefficient operation of the device.
-

All persons involved in commissioning, operating, maintaining and servicing the device must:

- be suitably qualified,
 - have sufficient knowledge of automated welding, and
 - read and carefully follow these operating instructions as well as the operating instructions for all system components.
-

The operating instructions must always be at hand wherever the device is being used. In addition to the operating instructions, attention must also be paid to any generally applicable and local regulations regarding accident prevention and environmental protection.

All safety and danger notices on the device

- must be in a legible state,
 - must not be damaged,
 - must not be removed,
 - must not be covered, pasted or painted over.
-

For the location of the safety and danger notices on the device, refer to the section headed "General" in the operating instructions for the device.

Before commissioning the device, rectify any faults that could compromise safety.

This is for your personal safety!

Proper use

The device is to be used exclusively for its intended purpose.

The device is intended solely for the electromagnetic cleaning of Fronius welding torches.

Any use above and beyond this purpose is deemed improper. The manufacturer shall not be held liable for any damage arising from such usage.

Proper use includes:

- carefully reading and following all the instructions given in the operating instructions
 - studying and obeying all safety and danger notices carefully
 - performing all stipulated inspection and servicing work.
-

The device is designed for use in industry and the workshop. The manufacturer accepts no responsibility for any damage caused through use in a domestic setting.

The manufacturer likewise accepts no liability for inadequate or incorrect results.

Environmental conditions

Operation or storage of the device outside the stipulated area will be deemed as not in accordance with the intended purpose. The manufacturer shall not be held liable for any damage arising from such usage.

Ambient temperature range:

- during operation: 0 °C to + 40 °C (32 °F to 104 °F)
 - during transport and storage: -25 °C to +55 °C (-13 °F to 131 °F)
-

Relative humidity:

- up to 50 % at 40 °C (104 °F)
 - up to 90 % at 20 °C (68 °F)
-

Keep ambient air free from dust, acids, corrosive gases and substances, etc.

Can be used at altitudes of up to 2000 m (6500 ft)

Obligations of the operator

The operator must only allow persons to work with the device who:

- are familiar with the fundamental instructions regarding safety at work and accident prevention and have been instructed in how to use the device
 - have read and understood these operating instructions, especially the section "safety rules", and have confirmed as much with their signatures
 - are trained to produce the required results.
-

Checks must be carried out at regular intervals to ensure that operators are working in a safety-conscious manner.

Obligations of personnel

Before using the device, all persons instructed to do so undertake:

- to observe the basic instructions regarding safety at work and accident prevention
 - to read these operating instructions, especially the "Safety rules" section and sign to confirm that they have understood them and will follow them.
-

Before leaving the workplace, ensure that people or property cannot come to any harm in your absence.

Specific hazards

Stay out of the working area of the robot.

The device must be incorporated into a higher-level safety system within a secured area.

If this area has to be accessed when setup and maintenance work is carried out, make sure that

- the entire system is switched off for the duration of the work in this area
 - and that it is prevented from starting up accidentally, e.g., as the result of a control fault
-

In addition to these operating instructions, the safety rules issued by the robot manufacturer must also be observed.

Covers and side panels may only be opened/removed while maintenance or repair work is being carried out.

During operation:

- Ensure that all covers are closed and all side panels are fitted properly.
 - Keep all covers and side panels closed.
-

Protecting yourself and others

Electromagnetic fields may pose as yet unknown risks to health:

- Effects on the health of persons in the vicinity, for example, those with pacemakers, metallic implants and hearing aids
 - Forbidden for anyone wearing a pacemaker: people wearing a pacemaker must consult their doctor before working with the device or entering its immediate vicinity
 - Forbidden for anyone with metal implants: people who have had metal implants fitted must consult their doctor before working with the device or entering its immediate vicinity
-

Magnetic fields generated by the high amperage can cause ferromagnetic parts such as spatter accumulations to be ejected from the cleaning opening. To prevent injury, never look into in the cleaning opening while the device is switched on; protective goggles with side protection must be worn at all times.

Anyone working with the device exposes themselves to numerous risks e.g.:

- flying sparks and hot pieces of metal
 - Arc radiation, which can damage eyes and skin
 - Risk of electrocution from mains current and welding current
 - Greater noise pollution
 - Harmful welding fumes and gases
-

Suitable protective clothing must be worn when working with the device. The protective clothing must have the following properties:

- Flame-resistant
 - Insulating and dry
 - Covers the whole body, is undamaged and in good condition
 - Safety helmet
 - Trousers with no turn-ups
-

Protective clothing refers to a variety of different items. Operators should:

- Protect eyes and face from UV rays, heat and sparks using a protective visor and regulation filter
- Wear regulation protective goggles with side protection behind the protective visor
- Wear stout footwear that provides insulation even in wet conditions
- Protect the hands with suitable gloves (electrically insulated and providing protection against heat)
- Wear ear protection to reduce the harmful effects of noise and to prevent injury

Keep all persons, especially children, out of the working area while any devices are in operation or welding is in progress. If, however, there are people in the vicinity:

- make them aware of all the dangers (dazzling by arc, injury from flying sparks, inhalation of harmful welding fumes, noise, possible danger from mains or welding current, possible danger from electromagnetic fields, possible danger from the magnetic field around the cleaning opening, mechanically-powered parts, compressed air/parting agent mixture ejected from the cleaning opening, flying shavings and similar matter, etc.),
- Provide suitable protective equipment
- Alternatively, erect suitable safety screens/curtains.

Risks from mains current and operating current

An electric shock is potentially life threatening and can be fatal.

Do not touch live parts either inside or outside the device.

All cables and leads must be secured, undamaged, insulated and adequately dimensioned. Loose connections, scorched, damaged or inadequately dimensioned cables and leads must be replaced immediately.

Do not sling cables or leads around the body or parts of the body.

Only switch on the device when all output connections have been established correctly.

The device must only be operated on a mains supply with a ground conductor and a socket with a ground conductor contact.

If the device is operated on a mains supply without a ground conductor, this will be deemed as gross negligence. The manufacturer shall not be held liable for any damage arising from such usage.

Arrange for the mains cable to be checked regularly by a qualified electrician to ensure the ground conductor is functioning properly.

Switch off unused devices.

Disconnect the mains plug before working on the device.

Attach a clearly legible and easy-to-understand warning sign to the device to prevent anyone from plugging the mains plug back in and switching it on again.

After opening the device:

- Discharge all live components
- Ensure that all components in the device are de-energised.

If work on live parts is required, appoint a second person to switch off the main switch at the right moment.

The housing screws provide an adequate ground conductor connection for earthing the housing. The screws must never be replaced with different screws unless a reliable ground conductor connection is set up.

EMC Device Classifications

Devices in emission class A:

- Are only designed for use in industrial settings
- Can cause line-bound and radiated interference in other areas

Devices in emission class B:

- Satisfy the emissions criteria for residential and industrial areas. This is also true for residential areas in which the energy is supplied from the public low-voltage mains.

EMC device classification as per the rating plate or technical data.

EMC measures

Warning, electromagnetic field. Electromagnetic fields may pose as yet unknown risks to health.

It is the operator's responsibility to ensure that no electromagnetic interference occurs in electrical and electronic devices.
If electromagnetic interference is detected, the operator is obliged to take action to rectify the situation.

Check for possible problems, and check and evaluate neighbouring devices' resistance to interference according to national and international requirements:

- Safety devices
- Power, signal and data transfer lines
- IT and telecommunications devices
- Measuring and calibrating devices
- Health of neighbouring persons

Supporting measures for avoidance of EMC problems:

1. Mains supply
 - If electromagnetic interference arises despite the correct mains connection, additional measures are necessary (e.g. use of a suitable line filter)
2. Shielding, if necessary
 - Shield off other nearby devices
 - Shield off entire welding installation
3. Do not have any magnetic or electronic data carriers about your person: magnetic or electronic data carriers can be damaged by the magnetic fields generated when the device is in use.
4. Do not have any watches or pieces of metal about your person. Watches can be damaged when the device is in use.

Safety measures at the installation location and during transport

A device toppling over could easily kill someone. Place the device on a solid, level surface such that it remains stable

- The maximum permissible tilt angle is 10°.

Special regulations apply in rooms at risk of fire or explosion

- Observe relevant national and international regulations.

Use internal work instructions and checks to ensure that the workplace environment is always clean and clearly laid out.

Only set up and operate the device in accordance with the degree of protection shown on the rating plate.

When setting up the Robacta TC and cleaning unit, ensure an all-round clearance of at least 0.5 m (19.69 in.) from any surrounding objects, e.g. walls, other devices or objects.

The Robacta TC and the cleaning unit must be set up at least 1 m (40 in.) away from computers, control lines and the welding process.

Position the Robacta TC and cleaning unit to prevent welding spatter coming into contact with the cleaning device.

Before transporting the device, allow parting agent to drain completely.

When transporting the device, observe the relevant national and local guidelines and accident prevention regulations. This applies especially to guidelines regarding the risks arising during transport.

After transporting the device, the device must be visually inspected for damage before commissioning. Any damage must be repaired by trained service technicians before commissioning the device.

Safety measures in normal operation

Only operate the device when all safety devices are fully functional. If the safety devices are not fully functional, there is a risk of

- injury or death to the operator or a third party,
- damage to the device and other material assets belonging to the operator,
- inefficient operation of the device.

Any safety devices that are not functioning properly must be repaired before switching on the device.

Never bypass or disable safety devices.

Before switching on the device, ensure that no one is likely to be endangered.

Check the device at least once a week for obvious damage and proper functioning of safety devices.

- Only use suitable original parting agent from the manufacturer.
- Observe the information on the parting agent safety data sheets when handling parting agent. The parting agent safety data sheets may be obtained from your service centre or downloaded from the manufacturer's website.
- Do not mix the manufacturer's parting agent with other parting agents.
- If damage results from using a different parting agent, the manufacturer accepts no liability. In addition, no warranty claims will be entertained.
- Used parting agent must be disposed of properly in accordance with the relevant national and international regulations.

Maintenance and repair

Under normal operating conditions, the device requires only a minimum of care and maintenance. However, it is vital to observe some important points to ensure it remains in a usable condition for many years.

- Before switching on, always check the mains plug and cable as well as charger leads and charging terminals for any signs of damage.
- If the surface of the device housing is dirty, clean with a soft cloth and solvent-free cleaning agent only

Maintenance and repair work must only be carried out by authorised personnel. Use only original replacement and wearing parts (also applies to standard parts). It is impossible to guarantee that bought-in parts are designed and manufactured to meet the demands made on them, or that they satisfy safety requirements.

Do not carry out any modifications, alterations, etc. to the device without the manufacturer's consent.

Dispose of in accordance with the applicable national and local regulations.

Safety inspection

The manufacturer recommends that a safety inspection of the device is performed at least once every 12 months.

A safety inspection should be carried out by a qualified electrician

- after any changes are made
 - after any additional parts are installed, or after any conversions
 - after repair, care and maintenance has been carried out
 - at least every twelve months.
-

For safety inspections, follow the appropriate national and international standards and directives.

Further details on safety inspection and calibration can be obtained from your service centre. They will provide you on request with any documents you may require.

Disposal

Waste electrical and electronic equipment must be collected separately and recycled in an environmentally responsible manner in accordance with the EU Directive and national law. Used equipment must be returned to the distributor or through a local, authorised collection and disposal system. Proper disposal of the old device promotes sustainable recycling of material resources. Ignoring this may lead to potential health/environmental impacts.

Packaging materials

Collected separately. Check your municipality's regulations. Reduce the volume of the box.

Safety symbols

Devices with the CE mark satisfy the essential requirements of the low-voltage and electromagnetic compatibility directives (e.g. relevant product standards of the EN 60 974 series).

Fronius International GmbH hereby declares that the device is compliant with Directive 2014/53/EU. The full text on the EU Declaration of Conformity can be found at the following address: <http://www.fronius.com>

Devices marked with the CSA test mark satisfy the requirements of the relevant standards for Canada and the USA.

Data protection

The user is responsible for the safekeeping of any changes made to the factory settings. The manufacturer accepts no liability for any deleted personal settings.

Copyright

Copyright of these operating instructions remains with the manufacturer.

The text and illustrations are all technically correct at the time of printing. We reserve the right to make changes. The contents of the operating instructions shall not provide the basis for any claims whatsoever on the part of the purchaser. If you have any suggestions for improvement, or can point out any mis-

takes that you have found in the instructions, we will be most grateful for your comments.

General

Device concept

The Robacta TC can be used to clean practically every torch shape. The compact design means it can be set up in the narrowest of spaces (for example, in robot cells). The cleaning device is more or less maintenance-free, as there are no mechanically stressed parts.

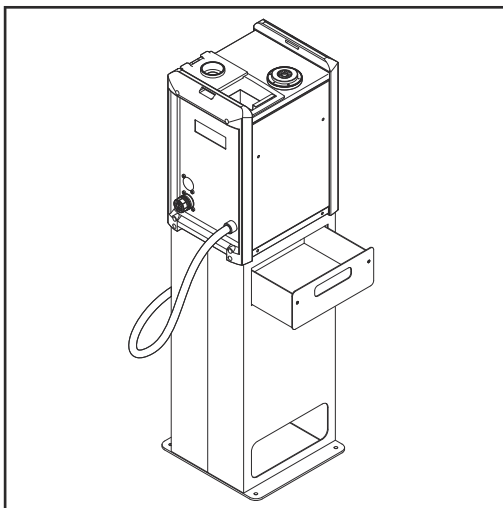

NOTE!

All of the components of the Robacta TC 1000 cleaning device are contained within one housing.

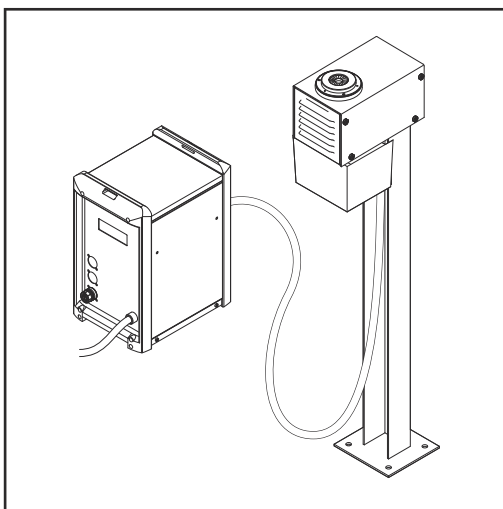

NOTE!

The components of the Robacta TC 1000 ext. are divided between two devices:

- ▶ Robacta TC 1000 ext. base unit
- ▶ Cleaning unit S. / cleaning unit P.

Robacta TC 1000 ext. (Base unit with cleaning unit S.)
Recommended for vertical torch cleaning

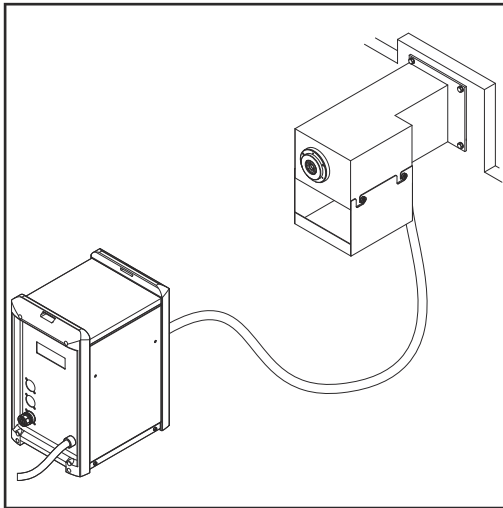

*Robacta TC 1000 ext. (Base unit with cleaning unit P.)
Recommended for horizontal torch cleaning*

All variants are also available in Twin and Twin Compact versions.

Application areas

The cleaning device cleans welding torches in automated steel applications. It has been designed for use in the

- automotive and component supply industry
- equipment construction
- chemical plant construction
- mechanical engineering
- rolling stock construction
- shipyards

Warning notices on the device

The device is fitted with safety symbols and a rating plate. The safety symbols and rating plate must not be removed or painted over. The symbols warn against operating the equipment incorrectly, as this may result in serious injury and damage.

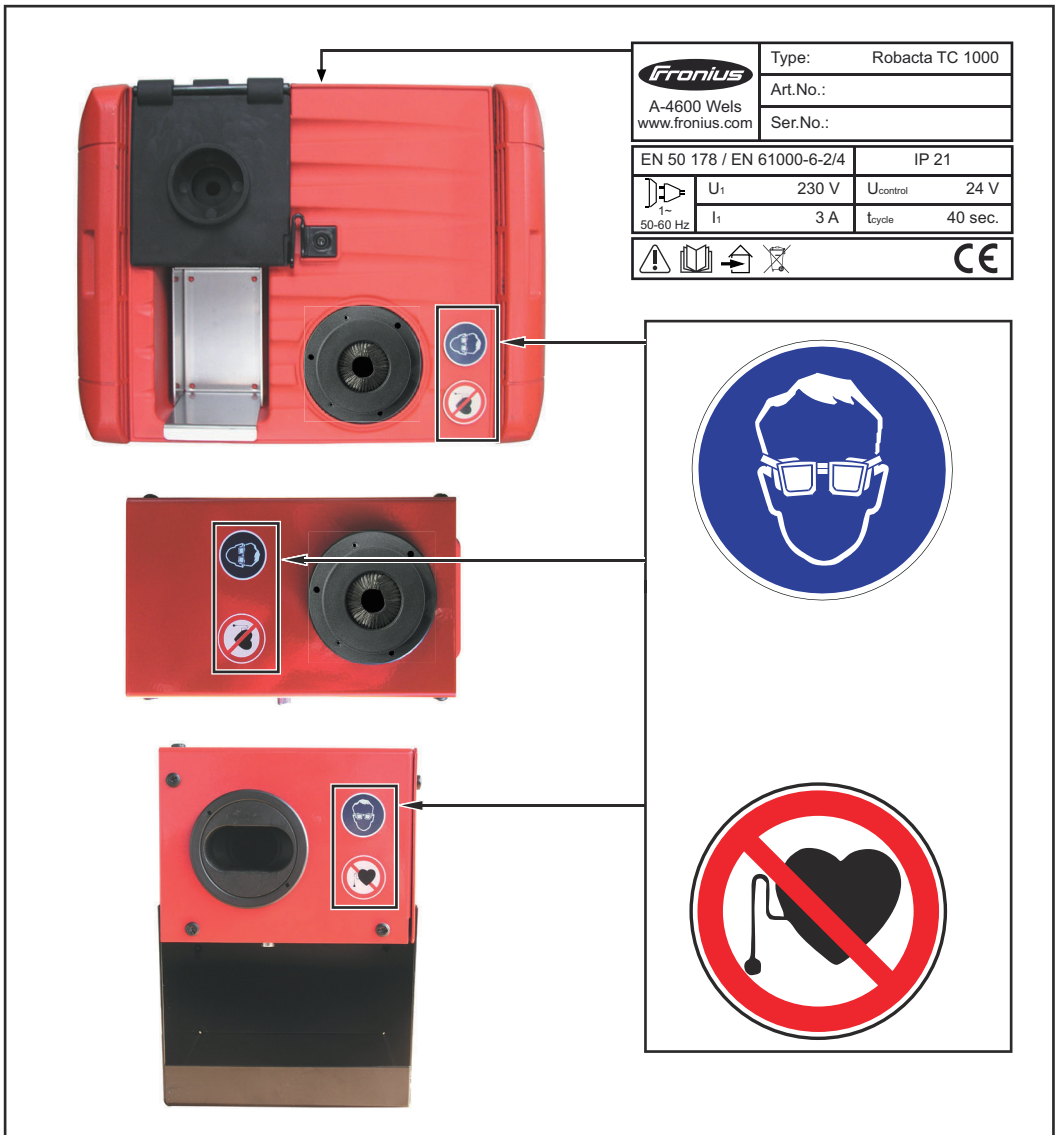

WARNING! Risk of serious injury from:

- the magnetic field surrounding the cleaning opening
- compressed air/parting agent mixture escaping from the cleaning opening
- flying parts (shavings, etc.)
- mechanically powered components

Keep device free from current and pressure during maintenance and servicing.



Do not use the functions described here until you have fully read and understood the following documents:

- These Operating Instructions
- All the Operating Instructions for the system components, especially the safety rules

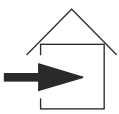

For indoor use only



Wear eye protection



Forbidden for anyone wearing a pacemaker. people wearing a pacemaker must consult their doctor before working with the device or entering its immediate vicinity

Parting agent types and their use

NOTE!

Parting agents are not included in the scope of supply.

Parting agent types and their use:

- "Robacta TC Cool +" parting agent for immersing the welding torch in the dipping bowl
- "Robacta Reamer" parting agent for spraying the welding torch after the cleaning operation

It is recommended that the dipping bowl should be used for:

- Gas-cooled welding torches
- Water-cooled welding torches in the upper power range (hot gas nozzles)

Spraying the welding torch with "Robacta Reamer" parting agent is recommended for all applications.

Functional principle

Functional principle

- a) Once the Robacta TC is connected to the mains power supply, the Mains voltage indicator (page 28) lights up. The capacitors, which store energy for the cleaning operation, are discharged and no outputs are activated.

NOTE!

The following prerequisites must be met before the capacitor charging process can begin

- ▶ Robacta TC 1000
- ▶ Device connected to the mains and the robot control
- ▶ The Quick Stop signal has been set
- ▶ Robacta TC 1000 ext.
- ▶ Base unit connected to the mains and the robot control
- ▶ Cleaning unit interconnecting hosepack connected to the base unit
- ▶ The Quick Stop signal has been set

- b) The device temperature is checked before the capacitors are charged. If it lies within the tolerance range, the capacitors are charged. If the operating temperature is exceeded, the Overtemperature indicator (page 28) lights up. If this is the case, the capacitors are only charged once the device has cooled down to the permissible operating temperature.
- c) Once the capacitors have been charged, the Ready signal is transmitted to the robot control - the Ready-to-clean indicator (page 28) lights up. The cleaning operation (discharge process) can now be initiated by means of the Cleaning Start signal. For adjustment purposes, the cleaning operation can also be manually triggered using the Discharge key button (page 28).
- d) Once the cleaning operation is complete, the program sequence restarts by checking the device's temperature. If a problem occurred during the cleaning operation, the Error. signal is output. The Robacta TC initiates the capacitor charging process again. Once ready to discharge (Ready), a second cleaning operation can be started.
- e) Automatic refilling of the dipping bowl from the "Robacta TC Cool / Robacta TC Cool MD" parting agent container ensures the optimum fill level. After draining the "Robacta TC Cool / Robacta TC Cool MD" parting agent container, the fill level in the dipping bowl drops. The level sensor detects that the level has dropped too low and the Fill level indicator (page 28) lights up. At the same time, the Fluid Level Control signal is transmitted to the robot control.
- The cleaning function of the Robacta TC remains available even if the Fill level indicator (page 28) is illuminated.

NOTE!

If the robot control deactivates the Quick Stop, signal during the program sequence, the Robacta TC program sequence is interrupted immediately.

For safety reasons the capacitors are discharged via the cleaning coil.

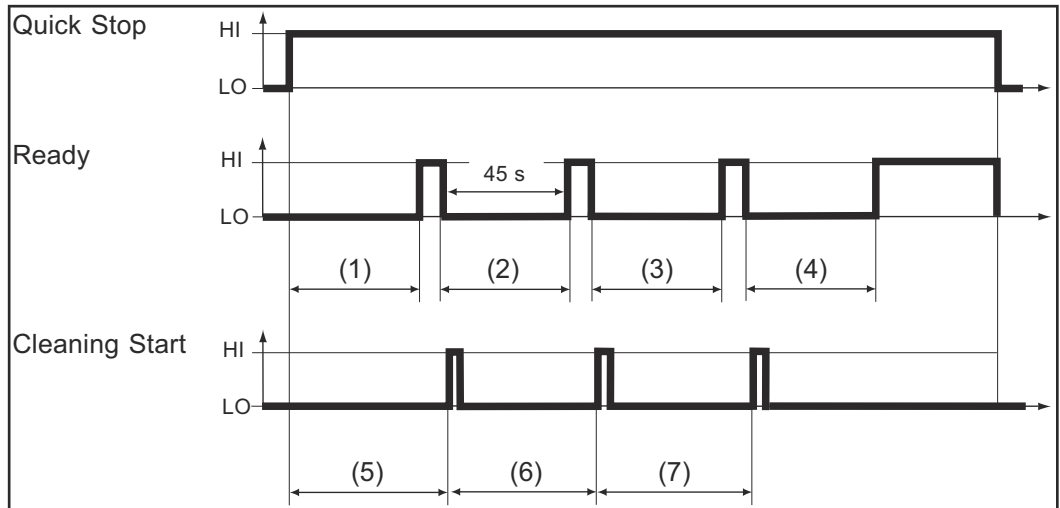

Diagram of the program sequence

(1) - (4) minimal cleaning interval

(5) - (7) cleaning interval

Scope of supply and options

General The cleaning devices can be used in conjunction with various options. This makes it possible to optimise various procedures in the welding process, as necessitated by the particular field of application.

Robacta TC 1000 scope of supply

- Robacta TC 1000 with dipping bowl and integral cleaning unit
- Standard I/O connecting plug (X1) without cable
- Compressed air interconnecting hosepack

Robacta TC 1000 options

Available options for the Robacta TC 1000

- Installation stand (available in various heights)
- Wire cutter
- Wire cutter installation kit
- Installation kit for parting agent nebuliser / parting agent nebuliser V
- Auto-transformer for 110 V and 400 V mains voltage
- Robot interface

Robacta TC 1000 ext. scope of supply

- Base unit (Robacta TC 1000 ext.)
- Standard I/O connecting plug (X1) without cable
- Compressed air interconnecting hosepack

NOTE!

Cleaning units S. and P. are not included in the base unit scope of supply, however they are needed in order to use the device.

Robacta TC 1000 ext. options

Available options for the Robacta TC 1000 ext.

- Cleaning unit S.
- Cleaning unit P.
- Installation stand (available in various heights)
- Auto-transformer for 110 V and 400 V mains voltage
- Robot interface
- Installation stand for cleaning units S. and P.
- Wire cutter
- Installation kit for parting agent nebuliser / parting agent nebuliser V

Transport

Transport devices

The device is to be transported by the following devices:

- On pallets using a forklift truck
- On pallets using a lift truck
- Manual



WARNING!

Danger from machines and objects falling.

This can result in serious injury and damage to property.

- ▶ Secure the device to prevent it from falling over when transporting on a forklift truck or lift truck.
 - ▶ Avoid sudden changes in direction, braking or acceleration.
-

Transport notices on the packaging



CAUTION!

Danger due to improper transport.

This can result in damage to property.

- ▶ Observe the transport notices on the device packaging.
-

Controls, connections and mechanical components

Safety

Observe the following safety rules for all work described in the "Control elements, connections and mechanical components" section.



WARNING!

Danger due to incorrect operation and incorrectly performed work.

This can result in serious injury and damage to property.

- ▶ All the work and functions described in this document must only be carried out by trained and qualified personnel.
 - ▶ Read and understand this document.
 - ▶ Read and understand all the Operating Instructions for the system components, especially the safety rules.
-

Control panel

General

All functions of the cleaning unit are activated by the robot control. For adjustment, the cleaning operation can be manually triggered on the control panel.

NOTE!

The individual illustrations may differ slightly from your device.

However, the functioning of the controls and the connections is identical.

Control panel

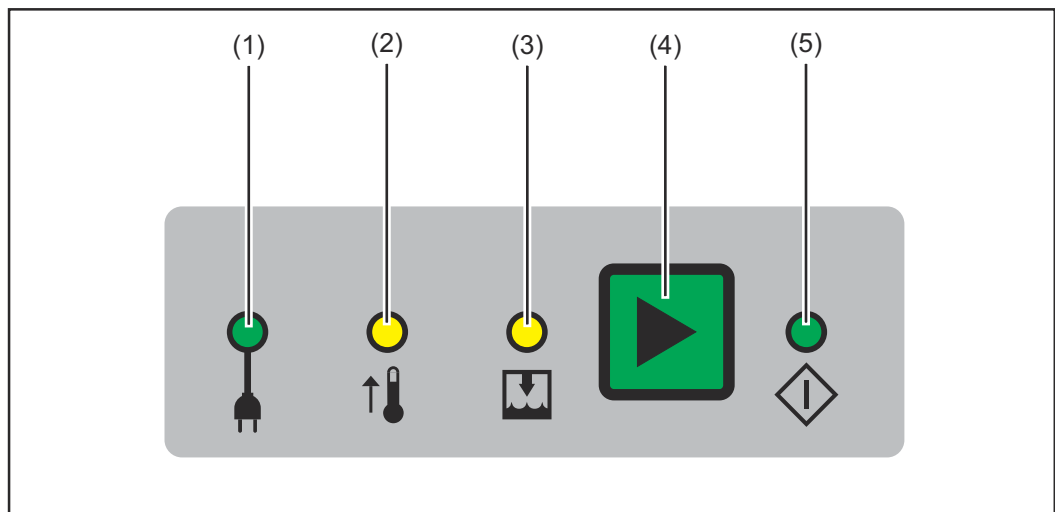

(1) Mains voltage indicator

lights up when the device is powered by mains voltage

NOTE!

If the capacitors in the device are charged, they will usually discharge automatically as soon as the device is unplugged from the mains. Discharge time is usually approx. 1 second.

If an error occurs, it is possible that the capacitors will not discharge. If this happens, you must follow the instructions in the [Fault procedure](#) section on page 78.

(2) Overtemperature indicator

lights up when the device overheats

NOTE!

One more cleaning operation can be carried out after this indicator lights up. Only once the device has cooled back down to the operating temperature will the device recharge in preparation for the next cleaning operation.

(3) Fill level indicator

will come on

- if the fill level in the dipping bowl drops below minimum
- if the dipping bowl is not used, hence there is no parting agent in the dipping bowl

NOTE!

If the dipping bowl is used, it should be refilled with parting agent as soon as the fill level indicator lights up.

NOTE!

The device cleaning function remains available even if the fill level indicator is illuminated.

(4) Discharge key

for starting the cleaning operation manually, e.g. for adjustment purposes

NOTE!

A cleaning operation can only be triggered manually if the Quick Stop signal is set and the capacitors are charged

(5) Ready-to-clean indicator

lights up when the device is ready to clean

**WARNING!****Risk of serious injury and damage from electric shock.**

Once the ready-to-clean indicator (5) lights up, the interconnecting hosepack must not be disconnected from the base unit.

- ▶ Before disconnecting the interconnecting hosepack:
 - ▶ Disconnect the base unit power supply
 - ▶ Disconnect the base unit compressed air supply
-

Robacta TC 1000

Robacta TC 1000 connections and mechanical components

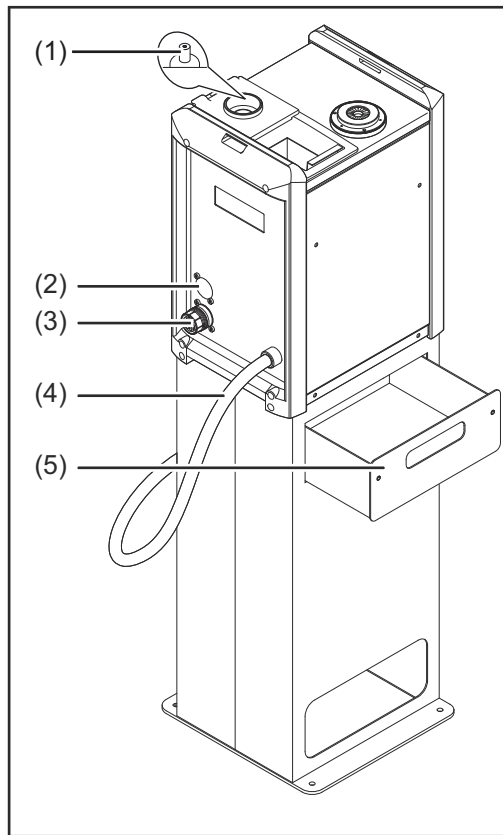

Front of device

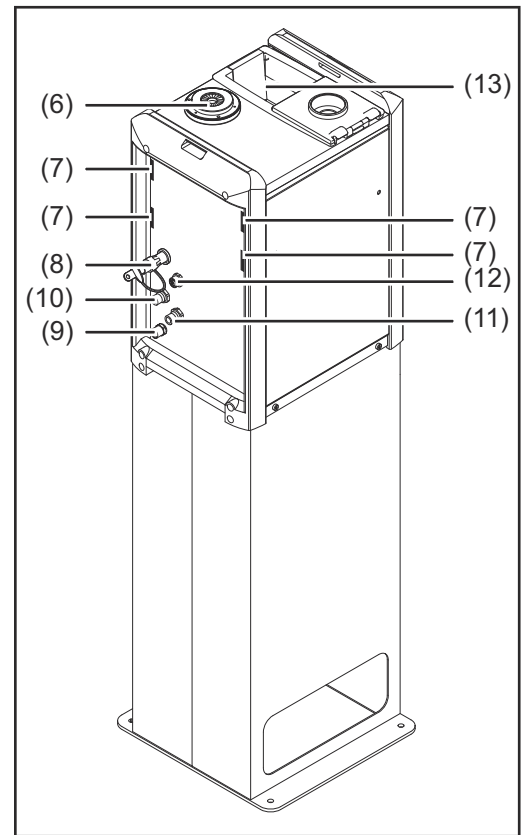

Rear of device

- | | |
|---|--|
| (1) | Level sensor
monitors the parting agent fill level in the dipping bowl |
| (2) | Blanking cover |
| (3) | Standard I/O connection socket (X1) |
| (4) | Mains cable with strain relief device |
| (5) | Spatter tray for welding residues (in optional installation stand) |
| (6) | Cleaning opening with internal parting-agent injection nozzle and brush seal
for cleaning the gas nozzle and the inside of the welding torch
for coating the gas nozzle and welding torch interior with parting agent |
| NOTE! | |
| To avoid excess soiling, only use the device with the brush seal in place. | |
| (7) | Recesses for the wire cutter holder
for attaching the wire cutter holder to the cleaning device |
| (8) | Drain hose
for emptying the dipping bowl |
| (9) | Compressed air connection
for supplying the cleaning device with compressed air |



(10) Parting agent nebuliser connection

for connecting to the parting agent nebuliser; to supply the parting agent nebuliser with compressed air



(11) Spray device connection

for connecting to the parting agent nebuliser; for spraying the compressed air/parting agent mixture into the cleaning opening

If a parting agent nebuliser is not used, connect parting agent nebuliser connection (10) to spray device connection (11). Use the supplied compressed air connecting hose for this purpose.



(12) Wire cutter connection socket

for electrically controlling the wire cutter



(13) Dipping bowl with spill tray**NOTE!**

Ensure that there is always sufficient parting agent in the dipping bowl when in use (i.e., ensure that the fill level indicator never lights up).

NOTE!

If the dipping bowl is not in use, ensure that there are no parting agent residues left in the bottom.

Base unit and cleaning unit P.

Base unit and cleaning unit P.

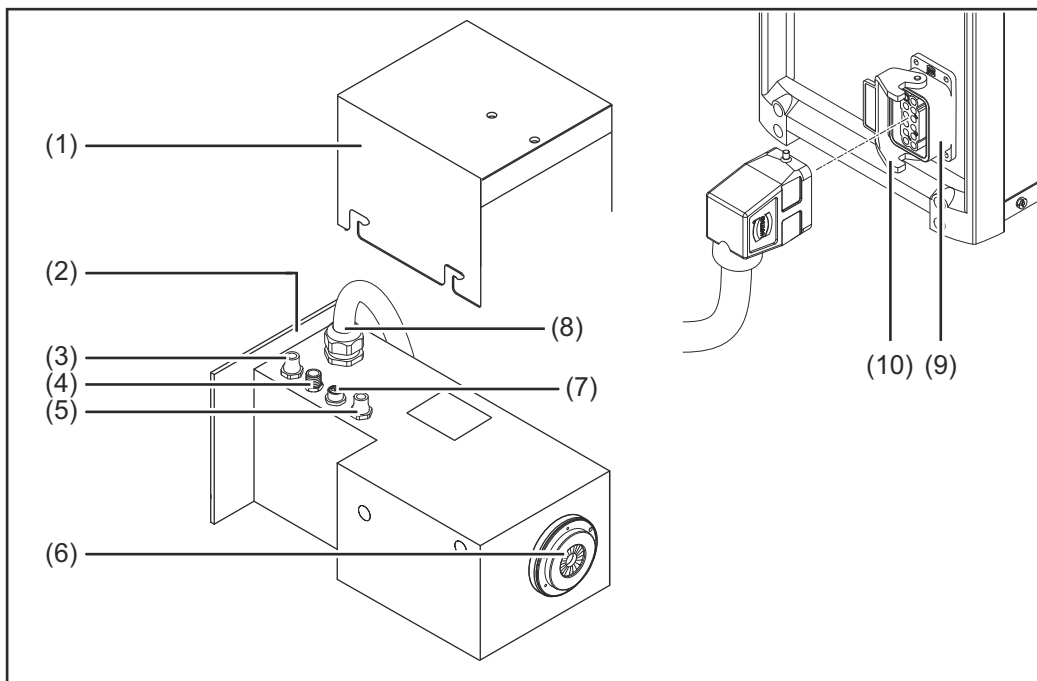

(1) **Spatter tray for welding residues**

(2) **Cleaning unit P.**

(3) **Spray device connection**

for connecting to the parting agent nebuliser; for spraying the compressed air/parting agent mixture into the cleaning opening

If a parting agent nebuliser is not used, connect parting agent nebuliser connection (5) to spray device connection (3). Use the supplied compressed air connecting hose for this purpose.



(4) **Compressed air connection**

for supplying the cleaning device with compressed air



(5) **Parting agent nebuliser connection**

for connecting to the parting agent nebuliser; to supply the parting agent nebuliser with compressed air



(6) **Cleaning opening with internal parting-agent injection nozzle and brush seal**

for cleaning the gas nozzle and the inside of the welding torch
for coating the gas nozzle and welding torch interior with parting agent

NOTE!

To avoid excess soiling, only use the device with the brush seal in place.

- (7) **Wire cutter connection socket**
for electrically controlling the wire cutter



- (8) **Interconnecting hosepack with strain-relief device**

WARNING!**Risk of serious injury and damage from electric shock.**

Once the ready-to-clean indicator lights up, the interconnecting hosepack must not be disconnected from the base unit.

- ▶ Before disconnecting the interconnecting hosepack:
- ▶ Disconnect the base unit power supply
- ▶ Disconnect the base unit compressed air supply

- (9) **Cleaning unit connection socket**
The connection socket is located on the base unit and is used to connect the cleaning unit interconnecting hosepack

NOTE!

Once the interconnecting hosepack is connected, turn the safety bow (10) to prevent the interconnecting hosepack being unintentionally disconnected.

- (10) **Safety bow**
- (11) **Base unit**
- (12) **Standard I/O connection socket (X1)**
for connecting the base unit to the robot control

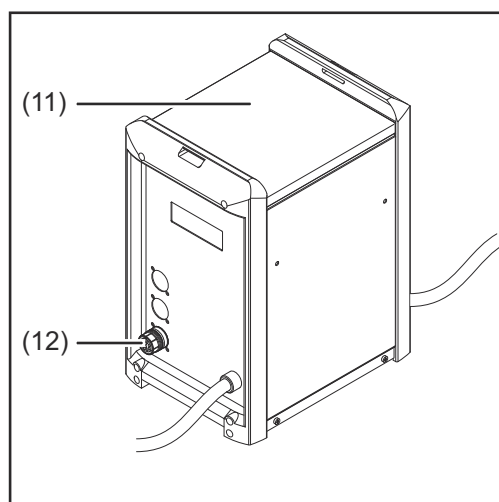

Base unit and cleaning unit S.

Base unit and cleaning unit S.

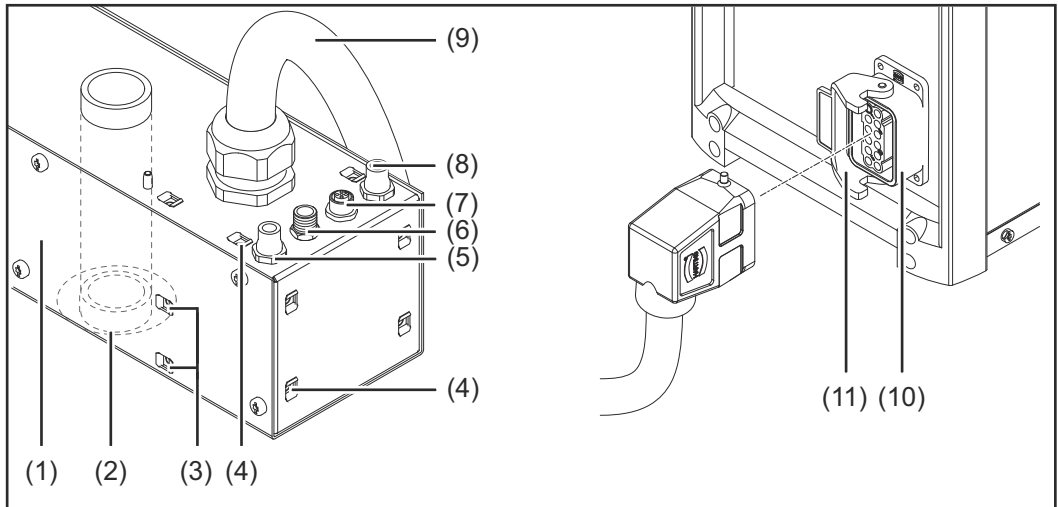

(1) Cleaning unit S.

(2) Cleaning opening with internal parting-agent injection nozzle and brush seal

for cleaning the gas nozzle and the inside of the welding torch
for coating the gas nozzle and welding torch interior with parting agent

NOTE!

To avoid excess soiling, only use the device with the brush seal in place.

(3) Fastening nuts

for attaching an optional wire cutter

(4) Fastening nuts

for fixing the cleaning unit in place

(5) Spray device connection

for connecting to the parting agent nebuliser; for spraying the compressed air/parting agent mixture into the cleaning opening

If a parting agent nebuliser is not used, connect parting agent nebuliser connection (8) to spray device connection (5). Use the supplied compressed air connecting hose for this purpose.



(6) Compressed air connection

for supplying the cleaning device with compressed air



(7) Wire cutter connection socket

for electrically controlling the wire cutter



(8) Parting agent nebuliser connection

for connecting to the parting agent nebuliser; to supply the parting agent nebuliser with compressed air



(9) Interconnecting hosepack with strain-relief device

⚠ WARNING!

Risk of serious injury and damage from electric shock.

Once the ready-to-clean indicator lights up, the interconnecting hosepack must not be disconnected from the base unit.

- ▶ Before disconnecting the interconnecting hosepack:
- ▶ Disconnect the base unit power supply
- ▶ Disconnect the base unit compressed air supply

(10) Cleaning unit connection socket

The connection socket is located on the base unit and is used to connect the cleaning unit interconnecting hosepack

NOTE!

Once the interconnecting hosepack is connected, turn the safety bow (11) to prevent the interconnecting hosepack being unintentionally disconnected.

(11) Safety bow

(12) Base unit

(13) Standard I/O connection socket (X1)

for connecting the base unit to the robot control

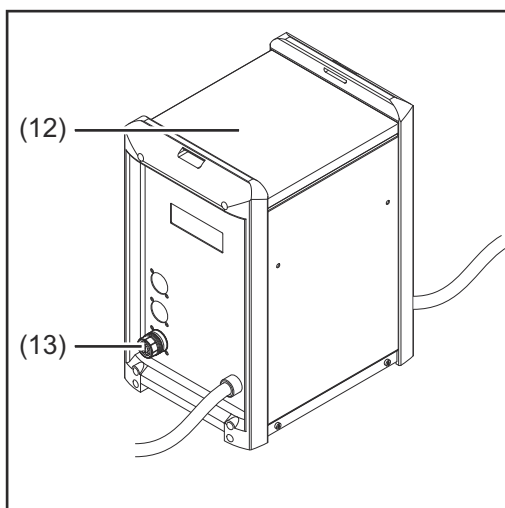

Standard I/O connecting plug (X1) pin assignment for robot control

General

 **WARNING!**

Danger from electric current.

This can result in serious personal injury and damage to property.

- ▶ The cleaning device must remain de-energised until the installation is fully complete.
-

NOTE!

To avoid malfunctions, keep the cable length between the cleaning device and robot control as short as possible.

The standard I/O connecting plug (X1) for connecting the cleaning device to the robot control is part of the scope of supply. Adapt the cable harness to the connection technology on the robot control.

Standard I/O connecting plug (X1) pin assignment

 **WARNING!**

Risk of serious injury and damage due to unexpected start-up of the cleaning device/system components.

Only assign the Quick Stop signal input once:

- ▶ either HIGH - Quick Stop
 - ▶ or LOW - Quick Stop
-

NOTE!

Depending on the demands placed on the robot application, not all input and output signals (commands) need to be used.

The underlined I/O signals represent the minimum command subset required in each instance.

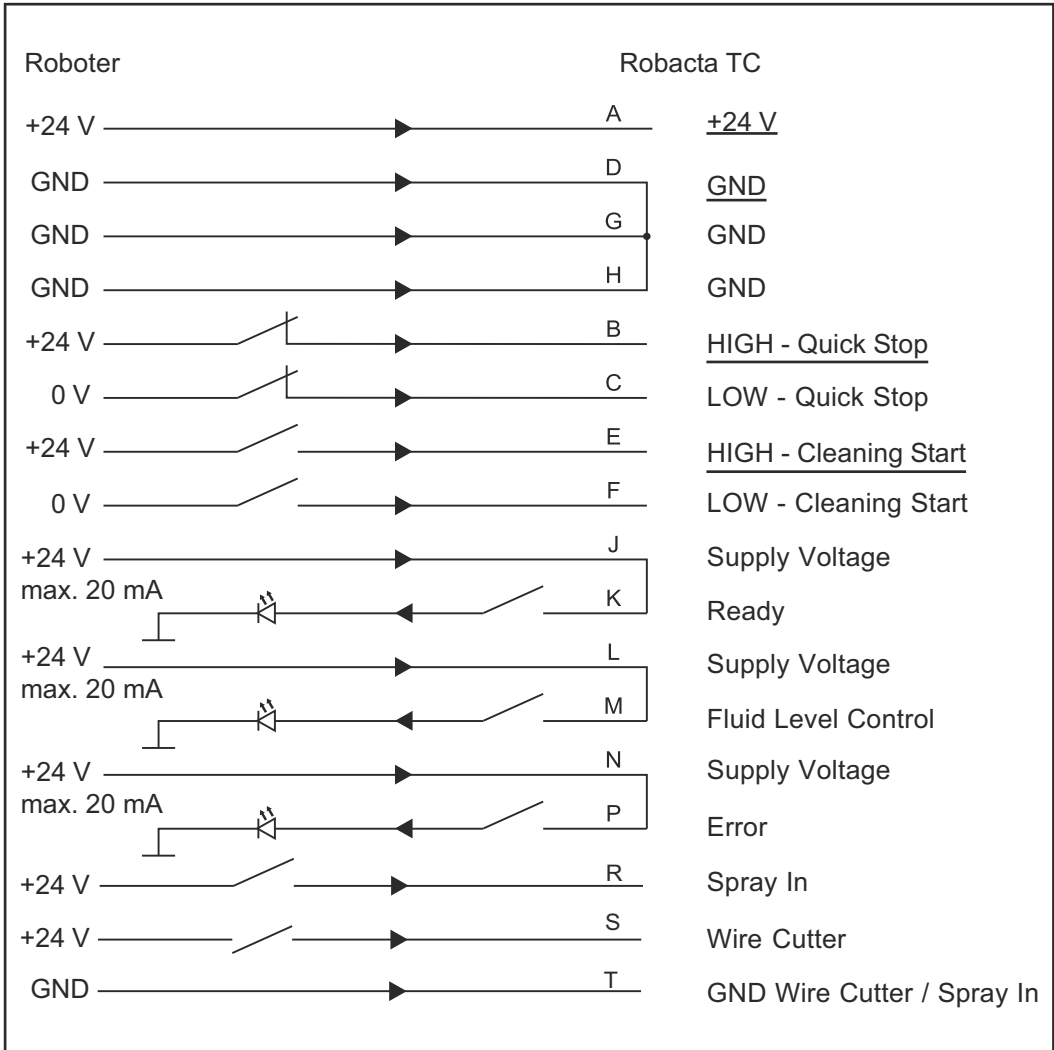

Standard I/O connecting plug (X1) pin assignment

Installation and commissioning

Safety

Observe the following safety rules for all work described in the "Installation and commissioning" section.

WARNING!

Danger from incorrect operation and work that is not carried out properly.

This can result in serious personal injury and damage to property.

- ▶ All the work and functions described in this document must only be carried out by a trained Fronius service technician.
- ▶ Read and understand this document in full.
- ▶ Read and understand all safety rules and user documentation for this device and all system components.

WARNING!

Risk of machines starting automatically.

This can result in serious personal injury and damage to property.

- ▶ In addition to these Operating Instructions, also observe the safety rules issued by the manufacturer of the robot and welding system.
- ▶ Ensure that all protective measures have been taken and will remain in place while you are in the working area of the robot.

WARNING!

Danger from electric current and mechanically powered parts.

This can result in serious personal injury and damage to property.

- ▶ Before working on the cleaning device or the associated system components, disconnect the customer's compressed air and power supply from the cleaning device and the associated system components.
- ▶ Ensure that they remain disconnected until all work is complete.

WARNING!

Whenever the cleaning device is supplied with voltage and/or compressed air, a risk of serious injury exists from:

the magnetic field of the cleaning opening

flying parts (shavings, etc.)

compressed air/parting agent mixture escaping from the cleaning opening

activated wire cutter

This can result in serious personal injury and damage to property.

If work has to be performed on the cleaning device while it is being supplied with voltage and/or compressed air, take the following protective measures:

- ▶ Keep all ferromagnetic parts away from the device (e.g. tools).
- ▶ Keep your body, especially your hands, face and hair, any objects and all clothing away from the cleaning opening and the wire cutter.
- ▶ Wear ear protection.
- ▶ Wear protective goggles with side protection.

Before commissioning

Operators, maintenance personnel

WARNING!

Risk of machines starting automatically.

This can result in serious injury and damage to property.

- ▶ The device must only be operated/serviced by 1 person at a time.
 - ▶ Ensure that there is only 1 person within the working area of the device when the device is being worked on.
-

Setup regulations

The cleaning device is tested to IP 21, meaning:

- protection against penetration by solid foreign bodies with diameters > 12.5 mm (0.49 in.)
- Protection against vertically falling drops of water

The device must not be set up and operated outdoors. The built-in electrical parts must be protected from direct wetting.

NOTE!

All components of the cleaning device must be:

- ▶ Set up at least 1 m (40 in.) away from computers, control lines and the welding process
 - ▶ Set up with an all-round clearance of at least 0.5 m (19.69 in.) from any surrounding objects, e.g. walls, other devices or objects
 - ▶ Positioned to prevent welding spatter coming into contact with the components of the cleaning device
-

Compressed air supply specifications

To ensure that the cleaning device functions correctly, the following compressed air supply specifications must be met:

- Establish compressed air supply using a pressure limiter and compressed air filter
 - Provide compressed air quality conforming to ISO 8573-1:2001, class 7 4 3, instrument air
 - Solid particle concentration $\leq 10 \text{ mg/m}^3$
 - Vapour pressure dew point $\leq + 3 \text{ }^\circ\text{C}$
 - Oil concentration $\leq 1 \text{ mg/m}^3$
-

Mains connection

WARNING!

Risk of serious injury and damage due to insufficiently dimensioned electrical installations.

The mains cable and its fuse must be dimensioned to suit the device being used. The technical data shown on the rating plate applies.



CAUTION!

Risk of serious damage as the result of incorrect mains voltage.

If the mains voltage lies outside the tolerances given in the technical data, do not under any circumstances connect the device directly to the mains. In this case, the device may only be operated using the optional auto-transformer.

The cleaning device is designed to run at the mains voltage indicated on the rating plate. The fuse protection required for the mains cable can be found in the "Technical data" section. If there is no mains cable or mains plug on your device, fit one that conforms to national standards.

Bolting the Robacta TC 1000 to the underlying surface (foundation)

Bolting the Robacta TC 1000 together with installation stand to the underlying surface (foundation)

WARNING!

Danger from machines toppling over or falling.

This can result in serious personal injury and damage to property.

- ▶ The cleaning device should only ever be set up with the designated installation stand.
- ▶ Different fixings may be required to connect the installation stand to the underlying surface depending on the nature of the surface.
- ▶ The fixings required to connect the installation stand to the underlying surface are not included in the scope of supply of the installation stand. The installer is responsible for selecting the right type of fixing. Only the screws needed to fit the cleaning device to the installation stand are supplied with the stand itself.

- 1** Place the optionally available installation stand on a level, firm and vibration-free surface
 - Position the installation stand in such a way that the distance the robot has to travel to the cleaning device on the installation stand is as short as possible
- 2** Screw the installation stand to the underlying surface using the appropriate fixings

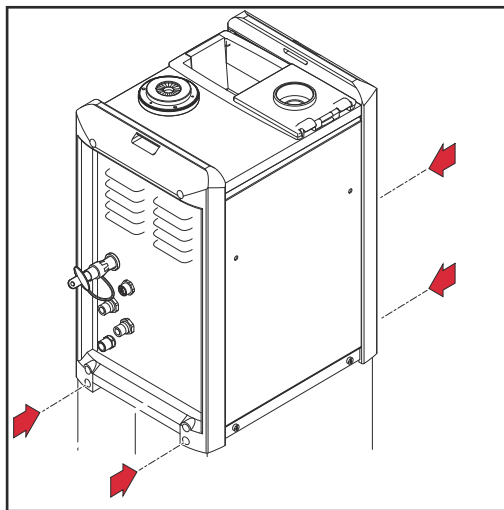

- 3** Position the cleaning device on the installation stand
- 4** Screw the cleaning device to the installation stand using the 4 screws supplied with the stand

Screw the base unit and cleaning unit to the underlying surface (foundation) and connect them to each other

Installation instructions

NOTE!

Before installing the base unit and the cleaning unit, ensure that the cleaning unit interconnecting hosepack is long enough for the intended installation positions.

Once the devices have been installed, the interconnecting hosepack must lie on the ground without being under any strain and must not hang in the air.

Screw the base unit and cleaning unit P. to the underlying surface (foundation) and connect them to each other

⚠ WARNING!

Risk of serious injury and damage from welding residues ejected from the cleaning opening on the cleaning unit.

Always position the cleaning unit so any ejected welding residues are caught directly in a suitable container at the cleaning station.

⚠ WARNING!

Danger from machines toppling over or falling.

This can result in serious personal injury and damage to property.

- ▶ Different fixings may be required to secure the individual components depending on the type of underlying surface (foundation).
- ▶ Fixings are therefore not included in the scope of supply of the individual components. The installer is responsible for selecting the right type of fixing.

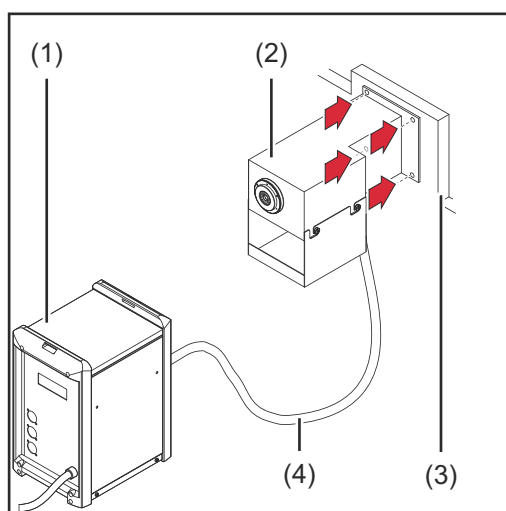

- 1** Position the base unit (1) securely outside the welding area on a level, firm and vibration-free surface and secure using the appropriate fixings
- 2** Use suitable fixings to bolt the cleaning unit (2) to the underlying surface (3)
- 3** Connect the interconnecting hosepack (4) to the Cleaning unit connection socket (page 32) on the base unit
- 4** Turn the safety bow on the cleaning unit connection socket to prevent the interconnecting hosepack being unintentionally disconnected

⚠ WARNING!

Danger from electrical current.

This can result in serious personal injury and damage to property.

- ▶ If the interconnecting hosepack needs to be disconnected after the base unit has been started up, carry out the following steps before disconnecting the interconnecting hosepack:
- ▶ Disconnect the base unit power supply
- ▶ Disconnect the base unit compressed air supply

Bolting the base unit and cleaning unit S. to the underlying surface (foundation) and connecting them to each other

⚠ WARNING!

Risk of serious injury and damage from welding residues ejected from the cleaning opening on the cleaning unit.

Always position the cleaning unit so any ejected welding residues are caught directly in a suitable container at the cleaning station.

⚠ WARNING!

Danger from machines toppling over or falling.

This can result in serious personal injury and damage to property.

- ▶ Different fixings may be required to secure the individual components depending on the type of underlying surface (foundation).
- ▶ Fixings are therefore not included in the scope of supply of the individual components. The installer is responsible for selecting the right type of fixing.

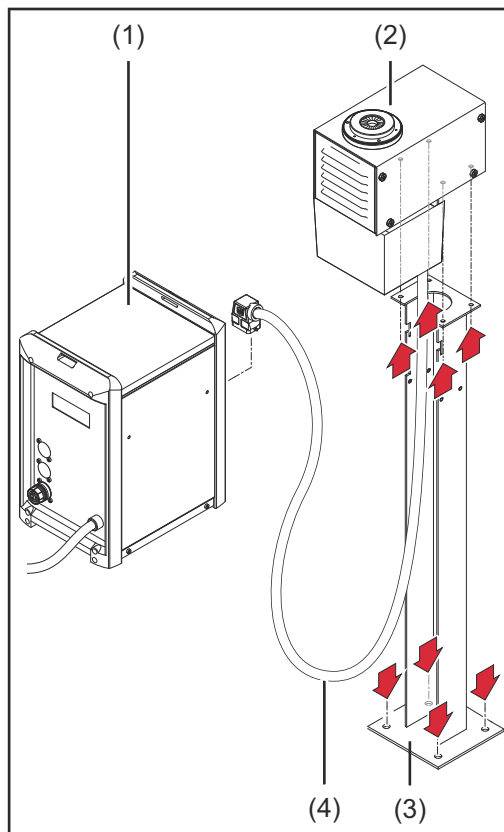

- 1 Position the base unit (1) securely outside the welding area on a level, firm and vibration-free surface and secure using the appropriate fixings
- 2 Position the installation stand (3) on a level, firm and vibration-free surface and secure using the appropriate fixings
- 3 Use suitable fixings to screw the cleaning unit (2) to the installation stand (3)
- 4 Connect the interconnecting hosepack (4) to the Cleaning unit connection socket (page 34) on the base unit
- 5 Turn the safety bow on the cleaning unit connection socket to prevent the interconnecting hosepack being unintentionally disconnected



WARNING!

Danger from electrical current.

This can result in serious personal injury and damage to property.

- ▶ If the interconnecting hosepack needs to be disconnected after the base unit has been started up, carry out the following steps before disconnecting the interconnecting hosepack:
 - ▶ Disconnect the base unit power supply
 - ▶ Disconnect the base unit compressed air supply
-

Installing the wire cutter

Installing the wire cutter on the Robacta TC 1000

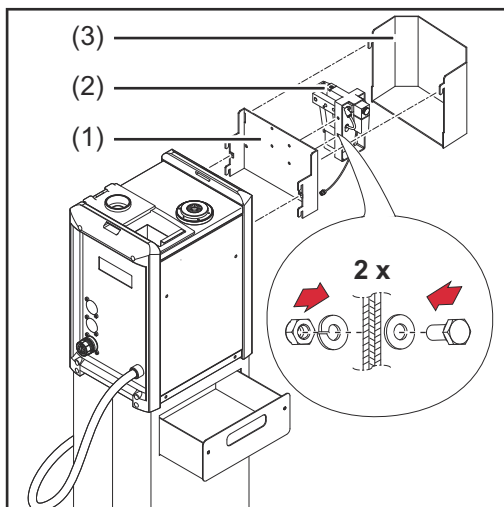

- 1 Attach the wire cutter holder (1) to the cleaning device
- 2 Fix the wire cutter (2) to the holder (1) using the two screws, two washers, two lock washers and two nuts as shown. The installer is responsible for selecting the correct screws, washers, lock washers and nuts
- 3 Attach the protective cover (3) to the holder (1)
- 4 If using an electrically controlled wire cutter: Plug the wire cutter connecting cable into the wire cutter connection socket on the cleaning device

NOTE!

The wire cutter cannot be supplied with compressed air from the cleaning device.

The wire cutter must be supplied with compressed air from a separate supply line.

Fitting the wire cutter to cleaning unit S

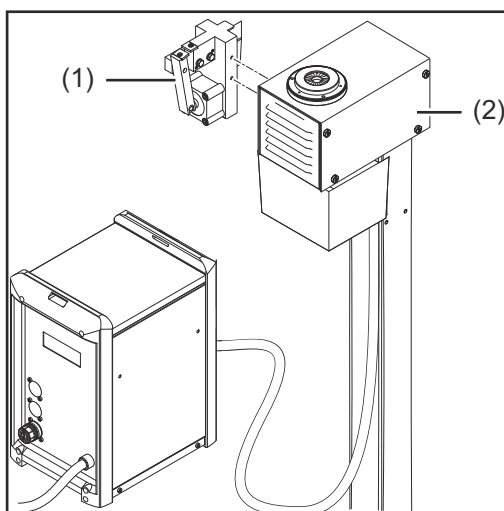

- 1 Using 2 screws and 2 lock washers, screw the wire cutter (1) onto the cleaning unit (2) fastening nuts. The installer is responsible for selecting the right screws and lock washers
- 2 If using an electrically-controlled wire cutter: Plug the wire cutter connecting cable into the wire cutter connection socket on the cleaning unit

NOTE!

The wire cutter cannot be supplied with compressed air from the cleaning unit.

The wire cutter must be supplied with compressed air from a separate supply line.

Fitting the wire cutter to cleaning unit P

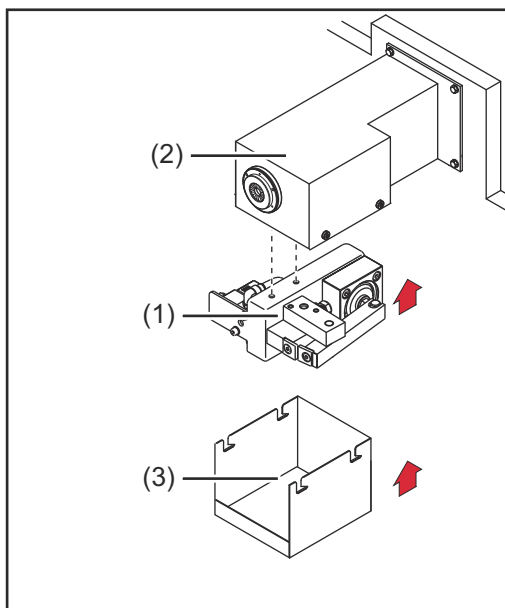

- 1** Screw the wire cutter (1) to the cleaning unit (2) using 2 screws, 2 washers, 2 lock washers and 2 nuts as shown. The installer is responsible for selecting the right screws, washers, lock washers and nuts
- 2** If using an electrically controlled wire cutter: Plug the wire cutter connecting cable into the wire cutter connection socket on the cleaning unit
- 3** Attach the spatter tray for welding residues (3) to the wire cutter

NOTE!

The wire cutter cannot be supplied with compressed air from the cleaning unit. The wire cutter must be supplied with compressed air from a separate supply line.

Maximum wire diameter

Wire electrodes with a diameter of up to 1.6 mm (0.063 in.) can be cut by the wire cutter.

Two wire electrodes with a diameter of up to 1.6 mm (0.063 in.) can be cut in the case of twin applications.

How the mechanically controlled wire cutter works

NOTE!

If you change over to a new welding torch, the mechanically controlled wire cutter must be reset!

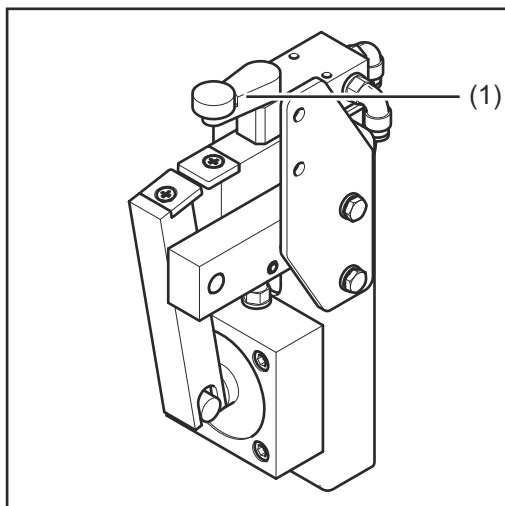

If a torch body pushes the valve lever (1) to the side by more than 15° with the gas nozzle, the wire cutter is activated and the wire electrode is cut.

NOTE!

The wire electrode is cut while the torch body is moving.

How the electrically-controlled wire cutter works

The electrically-controlled wire cutter opens and closes when there is an active signal from the robot control.

Filling the dipping bowl with parting agent

Filling the dipping bowl with parting agent

NOTE!

Only use the "Robacta TC Cool +" parting agent supplied by the manufacturer. The composition of the manufacturer's parting agent is intended specifically for the Robacta TC. If other manufacturers' products are used, trouble-free operation cannot be guaranteed.

- 1 Fold out the container holder containing the empty "Robacta TC Cool +" parting agent container
- 2 Remove the empty "Robacta TC Cool +" parting agent container and dispose of it according to national regulations
- 3 Open a new "Robacta TC Cool +" parting agent container and put it into the holder
- 4 Fold the container holder containing the full "Robacta TC Cool +" parting agent container carefully back above the dipping bowl
 - The optimum fill-level is regulated automatically

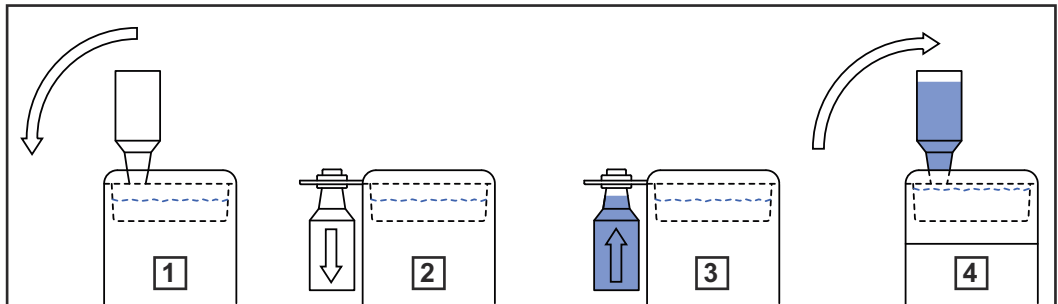

NOTE!

Carry out the following maintenance on the dipping bowl at weekly intervals:

- ▶ Take the spill tray out of the dipping bowl and dispose of any accumulated dirt
- ▶ Check the consistency of the "Robacta TC Cool +" parting agent. If the "Robacta TC Cool +" parting agent is thick, add fresh water and stir to mix in
- ▶ Check the level sensor in the dipping bowl for dirt and clean if necessary

NOTE!

Carry out the following maintenance on the dipping bowl every three months:

- ▶ Drain all the parting agent from the dipping bowl
- ▶ Take the spill tray out of the dipping bowl and dispose of any accumulated dirt
- ▶ Clean the dipping bowl and spill tray
- ▶ Fill the dipping bowl with new parting agent

Take care never to damage the level sensor when performing maintenance work.

Installing and commissioning the parting agent nebuliser (only for Robacta TC 1000)

Installing the parting agent nebuliser on the Robacta TC 1000

NOTE!

If the parting agent nebuliser is positioned too high, there is a risk of parting agent leaking out around the spray holes in the cleaning opening.
Position the parting agent nebuliser below the upper edge of the housing.

NOTE!

Ensure that the length of the parting agent hose between the device and the parting agent nebuliser does not exceed 1 m (40 in.).

- 1 Bolt the parting agent nebuliser to a level, firm and vibration-free surface. The installer is responsible for selecting the right type of fixing.

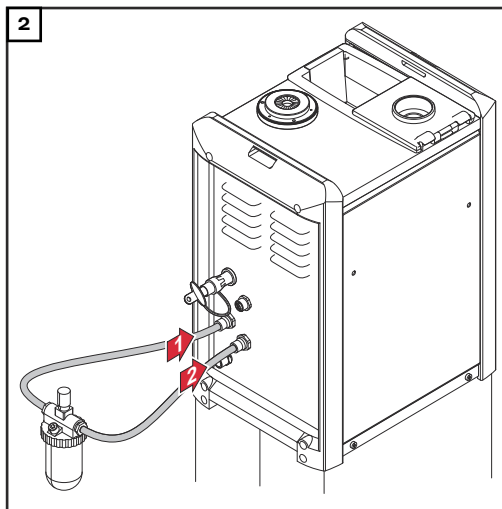

NOTE!

Use the parting agent hoses supplied with the parting agent nebuliser to connect the nebuliser to the cleaning device.

Starting up the parting agent nebuliser

NOTE!

Only use "Robacta Reamer" parting agent supplied by the manufacturer.

The composition of the manufacturer's parting agent is intended specifically for the Robacta TC. If other manufacturers' products are used, trouble-free operation cannot be guaranteed.

- 1 Open the sealing plug (1)
- 2 Fill with "Robacta Reamer" parting agent using the funnel (2)
- 3 Close the sealing plug (1)

NOTE!

If the spray amount is not sufficient, increase it as required

- ▶ by adjusting the spray time using the robot control - a spray time of ~ 0.7 seconds is recommended
- ▶ or by using the parting agent adjuster (4): remove the safety clamp (3), use a screwdriver to set the parting agent adjuster (4) so that the welding torch interior is coated with a thin layer of parting agent (0.2-0.5 ml) after the spraying action is complete

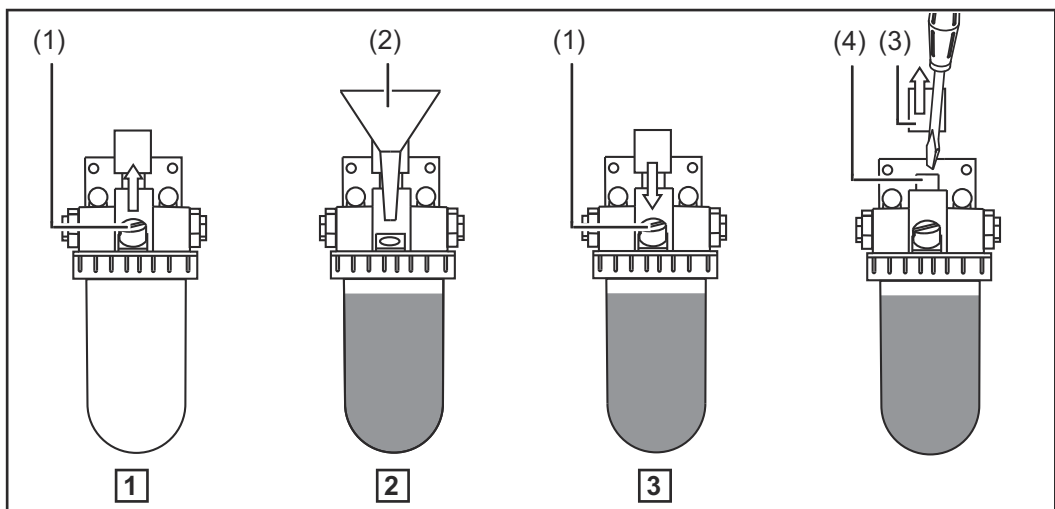

Starting up the parting agent nebuliser V

Robacta TC 1000: Installing parting agent nebuliser V

NOTE!

If the parting agent nebuliser is positioned too high, there is a risk of parting agent leaking out around the spray holes in the cleaning opening. Position the parting agent nebuliser below the upper edge of the housing.

NOTE!

Ensure that the length of the parting agent hose between the device and the parting agent nebuliser does not exceed 1 m (40 in.).

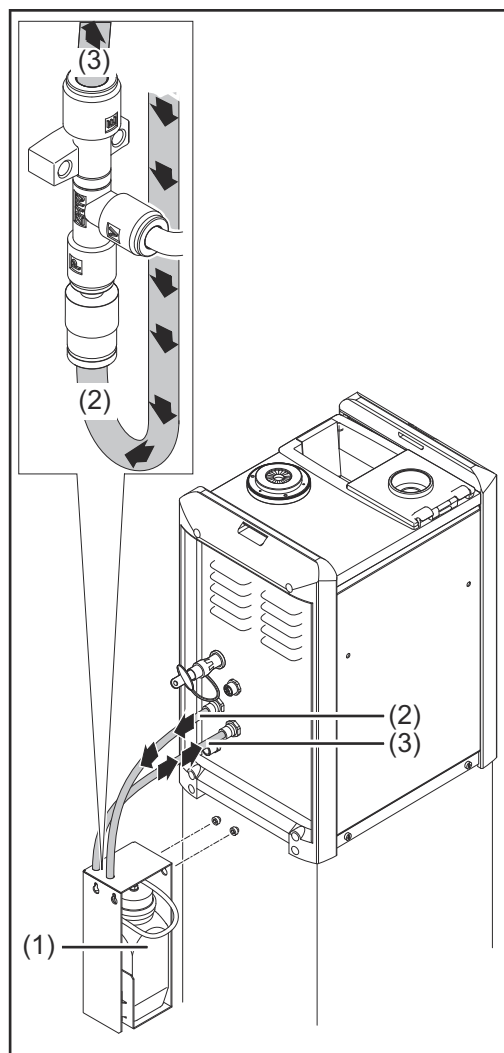

- 1 Use two screws to secure the parting agent nebuliser (1) to the cleaning unit installation stand as shown using the screws supplied with the parting agent nebuliser

NOTE!

Use the parting agent hoses supplied with the parting agent nebuliser to connect the nebuliser to the cleaning device.

- 2 Connect the parting agent hose (2) to the parting agent nebuliser connection on the cleaning device
 - Compressed air supply from the cleaning device
- 3 Connect the parting agent hose (3) to the spray device connection on the cleaning device
 - Compressed air/parting agent mixture supply to the cleaning device

NOTE!

The parting agent spray time must be set on the robot control.

- ▶ A spray time of approximately 0.7 seconds is recommended. This may vary depending on the size of the gas nozzle.

Cleaning unit S.: Installing parting agent nebuliser V

NOTE!

If the parting agent nebuliser is positioned too high, there is a risk of parting agent leaking out around the spray holes in the cleaning opening. Position the parting agent nebuliser below the upper edge of the housing.

NOTE!

Ensure that the length of the parting agent hose between the device and the parting agent nebuliser does not exceed 1 m (40 in.).

- 1 Screw the parting agent nebuliser (1) to the cleaning unit (2) installation stand using 2 screws, 2 washers, 2 lock washers and 2 nuts as shown. The installer is responsible for selecting the right screws, washers, lock washers and nuts

NOTE!

Use the parting agent hoses supplied with the parting agent nebuliser to connect the nebuliser to the cleaning unit.

- 2 Connect the parting agent hose (3) to the parting agent nebuliser connection on the cleaning unit
 - Compressed air supply from the cleaning unit
- 3 Connect the parting agent hose (4) to the spray device connection on the cleaning unit
 - Compressed air/parting agent mixture supply to the cleaning unit

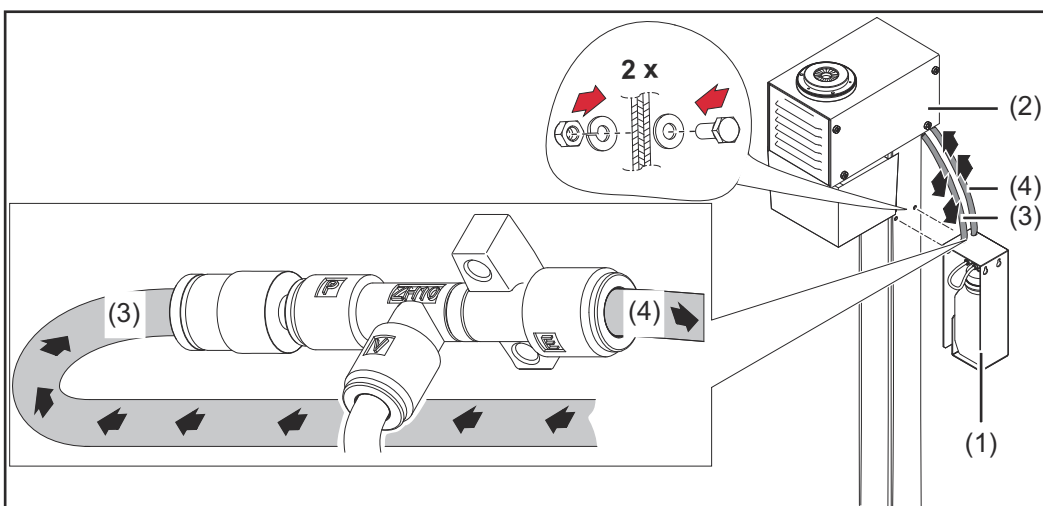
**NOTE!**

The parting agent spray time must be set on the robot control.

- ▶ A spray time of approximately 0.7 seconds is recommended. This may vary depending on the size of the gas nozzle.

Cleaning unit P: Installing parting agent nebuliser V

NOTE!

If the parting agent nebuliser is positioned too high, there is a risk of parting agent leaking out around the spray holes in the cleaning opening. Position the parting agent nebuliser below the upper edge of the housing.

NOTE!

Ensure that the length of the parting agent hose between the device and the parting agent nebuliser does not exceed 1 m (40 in.).

- 1 Bolt the parting agent nebuliser (1) to a level, firm and vibration-free surface close to the cleaning device (2). The installer is responsible for selecting the installation location and the right fixings

NOTE!

Use the parting agent hoses supplied with the parting agent nebuliser to connect the nebuliser to the cleaning unit.

- 2 Connect the parting agent hose (3) to the parting agent nebuliser connection on the cleaning unit
 - Compressed air supply from the cleaning unit
- 3 Connect the parting agent hose (4) to the spray device connection on the cleaning unit
 - Compressed air/parting agent mixture supply to the cleaning unit

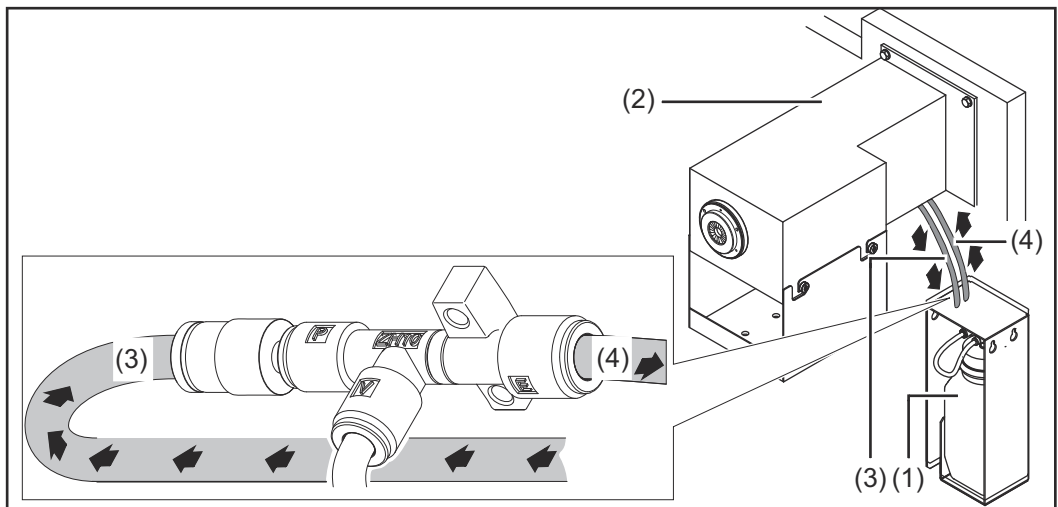

NOTE!

The parting agent spray time must be set on the robot control.

- A spray time of approximately 0.7 seconds is recommended. This may vary depending on the size of the gas nozzle.

Filling the "Robacta Reamer" parting agent container with parting agent

NOTE!

Only use "Robacta Reamer" parting agent supplied by the manufacturer.

The composition of the manufacturer's parting agent is intended specifically for the Robacta TC. If other manufacturers' products are used, trouble-free operation cannot be guaranteed.

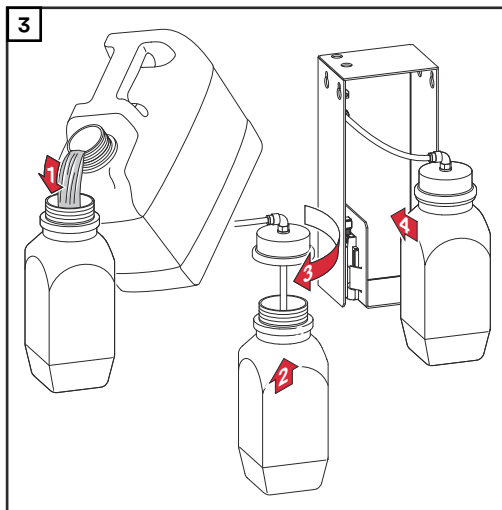
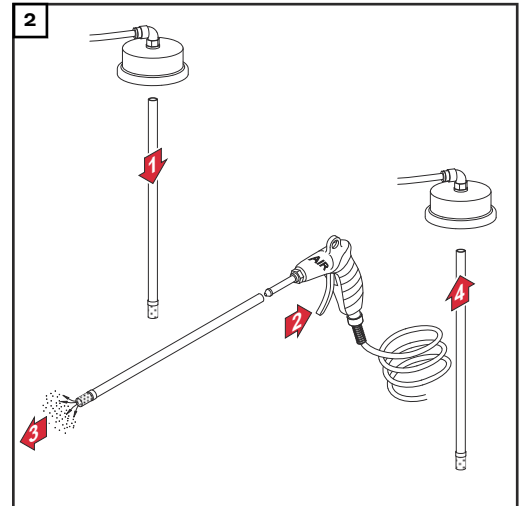
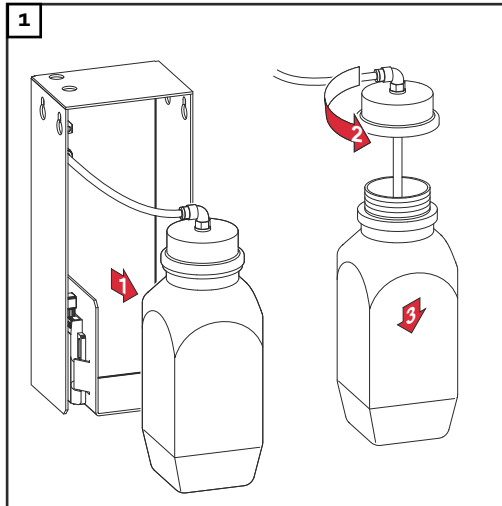

Connecting the 'Robacta Reamer' parting agent container (10 litres) to the cleaning device

- 1 Remove the existing 'Robacta Reamer' parting agent container (2) from the container housing
- 2 Disconnect the parting agent hose (1) from connection Y in the container housing

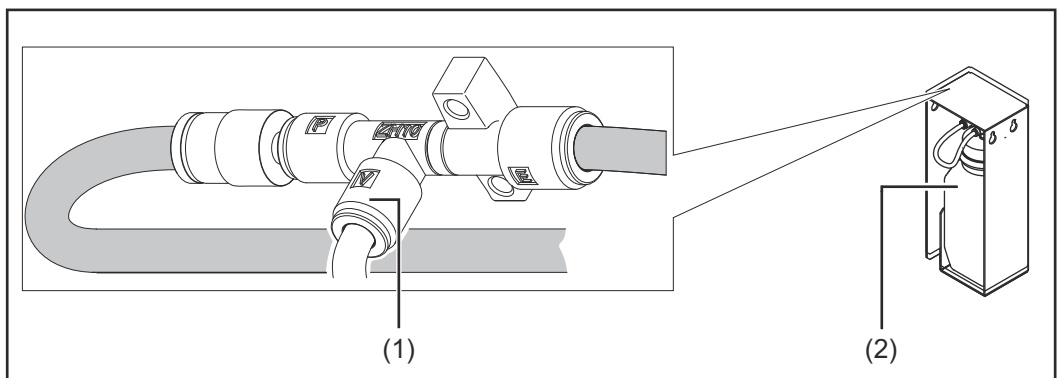

- 3 Prepare the 10-litre "Robacta Reamer" parting agent container as shown

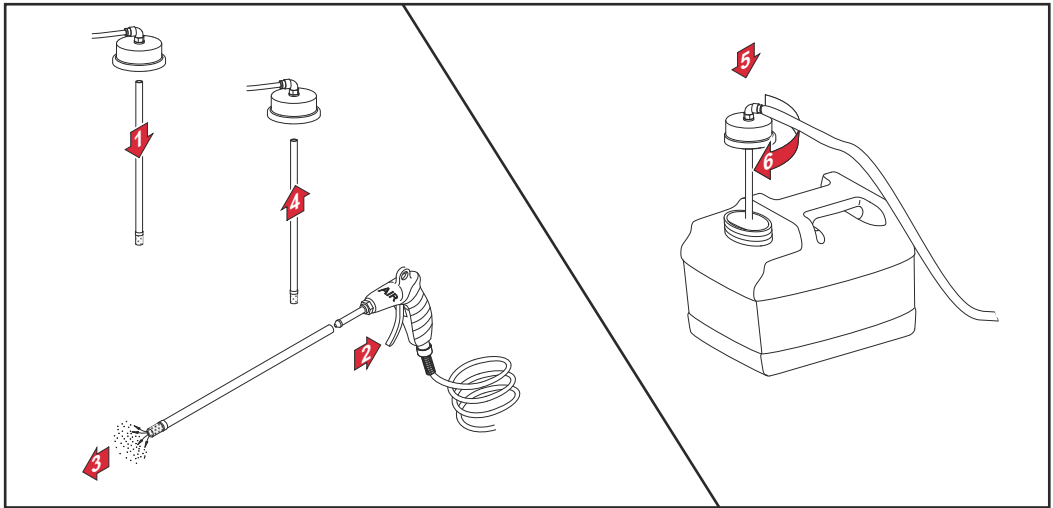

4 Connect the parting agent hose (3) to connection Y in the container housing

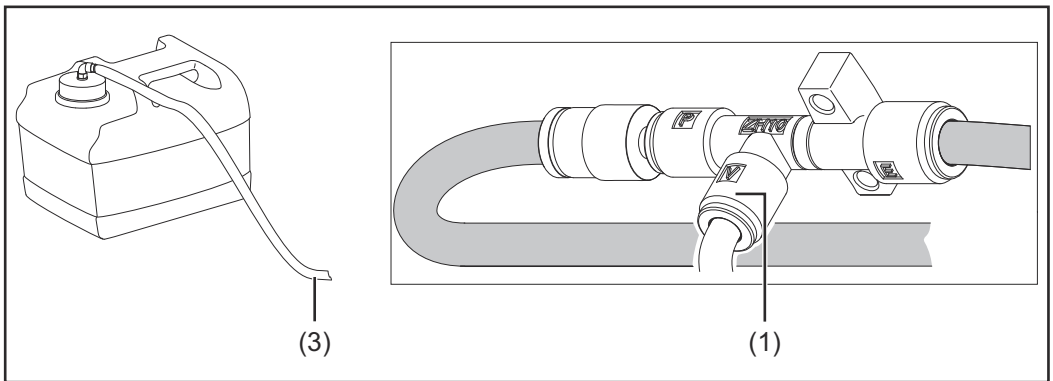

Fitting and using the fill-level control sensor

General

NOTE!

The fill-level control sensor can only be used in conjunction with parting agent nebuliser V.

Controls and indicators on the sensor

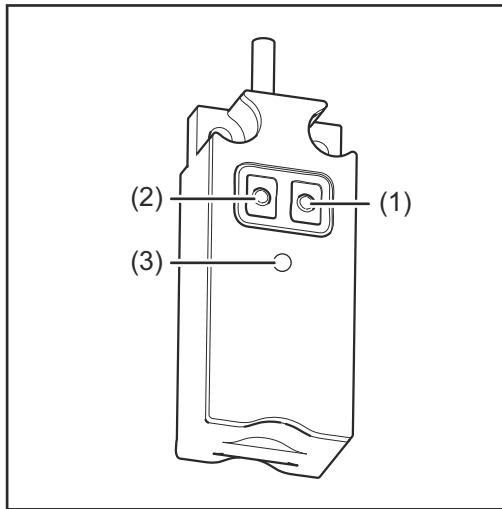

- (1) **'OUT OFF' button**
for programming the sensor
- (2) **'OUT ON' button**
for programming the sensor
- (3) **LED**
indicates the sensor operating status
 - LED on/flashing: sensor is active
 - LED on/not flashing: sensor is not active

Installation adapter borehole dimensions

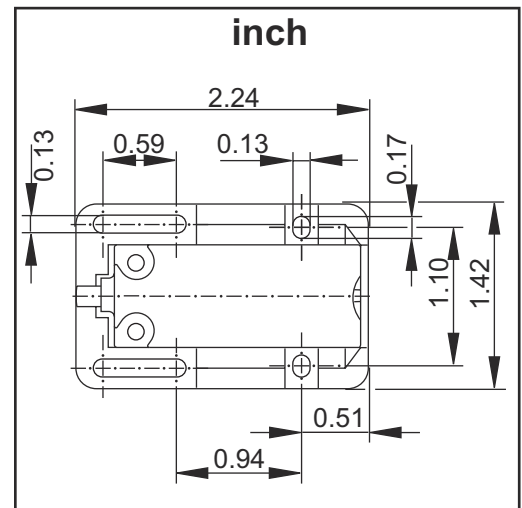
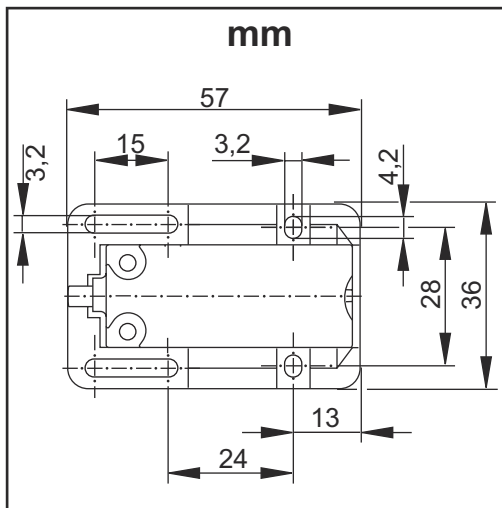

Fitting the fill-level control sensor

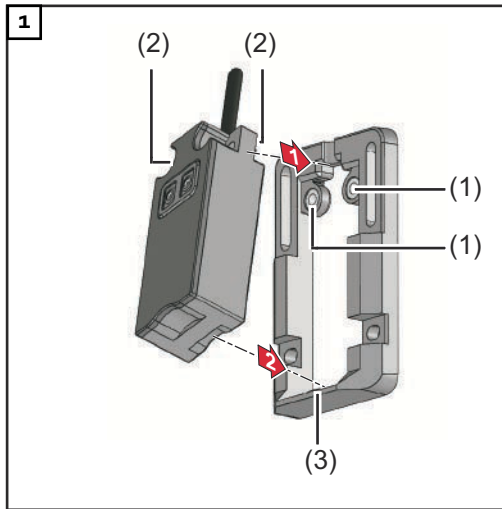

NOTE!

First press the upper part of the sensor into the installation adapter as shown - the sockets (1) on the installation adapter must fit into the recesses (2) in the sensor.

When the upper part of the sensor is properly lined up in the installation adapter, press the sensor fully into the installation adapter - the latch (3) on the installation adapter must snap back over the sensor (sensor audibly engages).

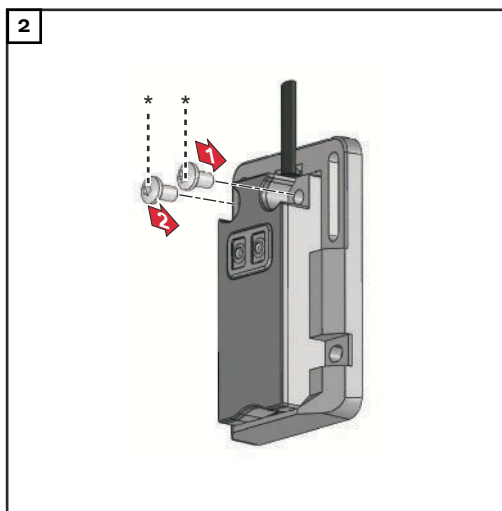

* Use the fixings supplied with the sensor.

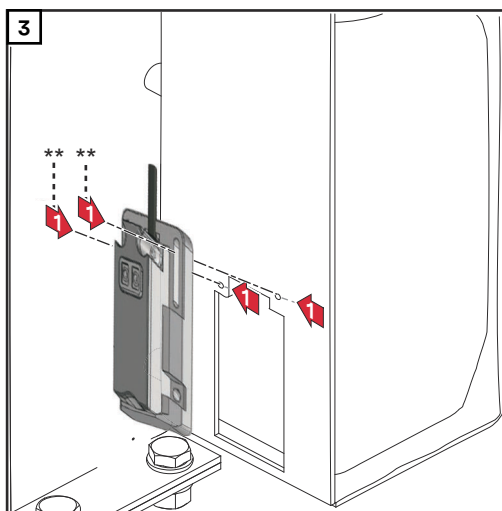

Screw the installation adapter and sensor on to the parting agent container housing

** Fixings are not included in the sensor/installation adapter scope of supply. The installer is responsible for selecting the right type of fixing.

NOTE!

Ensure the fixings do not damage the parting agent container.

Calibrating the empty state

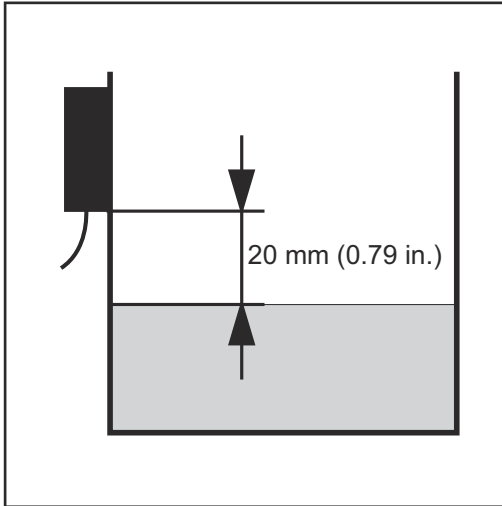

- 1 Drain the parting agent container until the parting agent level is at least 20 mm (0.787 in.) below the sensor
- 2 Establish a power supply to the sensor

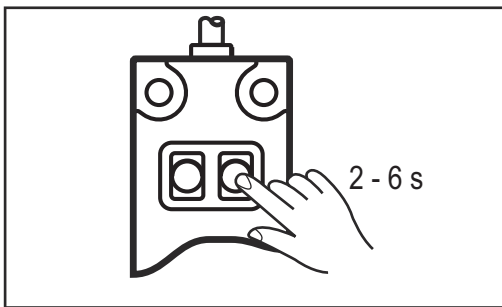

- 3 Press the "OUT OFF" button for between 2 and 6 seconds
 - The LED on the sensor flashes slowly
 - After releasing the "OUT OFF" button the LED goes out - the sensor has detected a low fluid level

Calibrating the full state

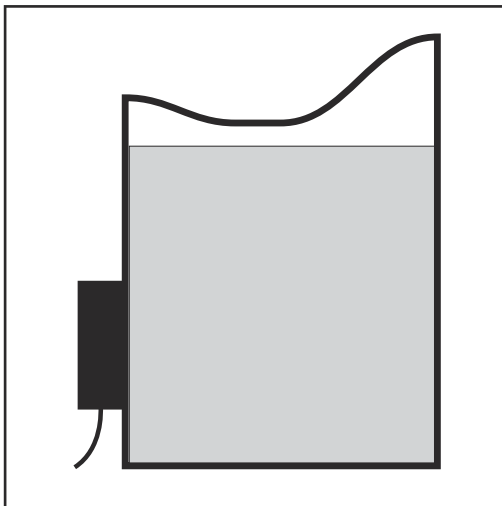

- 1 Fill the parting agent container with parting agent

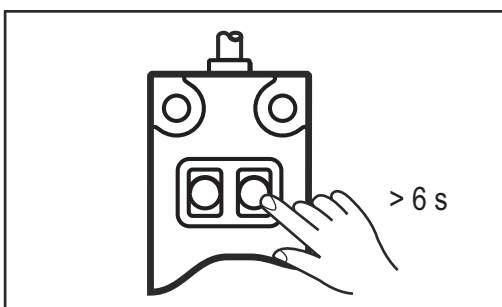

- 2 Press the "OUT OFF" button for at least 6 seconds
 - The sensor LED flashes slowly at first, then more rapidly after 6 seconds
 - After releasing the "OUT OFF" button the LED goes out - the sensor has detected a high fluid level

Locking/unlocking the fill-level control sensor

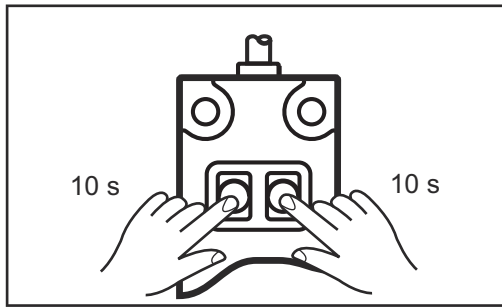

NOTE!

It is possible to lock the fill-level control sensor to prevent it from being adjusted accidentally.

Locking the fill-level control sensor:

- 1 Simultaneously press the "OUT OFF" and "OUT ON" buttons for at least 10 seconds
 - The LED status changes briefly
 - if the LED lights up when locking, it will go out briefly after locking
 - if the LED does not light up when locking, it will come on briefly after locking

Unlocking the fill-level control sensor:

- 1 Simultaneously press the "OUT OFF" and "OUT ON" buttons for at least 10 seconds
 - The LED status changes briefly
 - if the LED lights up when unlocking, it will go out briefly after unlocking
 - if the LED does not light up when unlocking, it will come on briefly after unlocking

Electrical connection

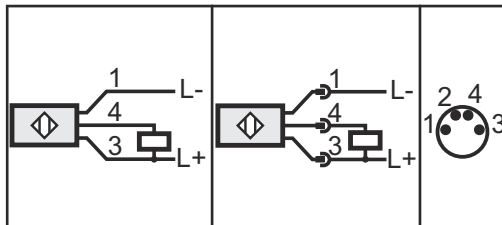

Wire colours:

1. brown
2. blue
3. blue
4. black

Starting up the cleaning device

General

NOTE!

Not coating the interior of the welding torch may result in permanent soiling of the torch when welding begins.

Always wet the inside of the welding torch with the manufacturer's "Robacta Reamer" parting agent before starting automatic operation.

To achieve the best cleaning results, please note the following:

- Apply an even layer of parting agent to the inside of the torch
- Follow the cleaning sequences as described below
- Keep to the specified cleaning positions
- Blow out the welding torch with compressed air during the cleaning operation (however not when parting agent is being actively sprayed into the torch interior)

NOTE!

Single, small bits of welding spatter cannot be removed by the cleaning device.

However, these small pieces do not influence the welding process.

Prerequisites for start-up

The following requirements must be met before the Robacta TC 1000 is started up:

- Cleaning device is bolted to underlying surface (foundation)
- Cleaning device connected to mains
- Cleaning device is connected to the robot control

The following requirements must be met before the Robacta TC 1000 ext. is started up:

- The base unit is screwed to the underlying surface
- The cleaning unit is screwed to the underlying surface
- Cleaning unit interconnecting hosepack connected to the base unit
- Base unit connected to mains
- The cleaning unit is supplied with compressed air
- Base unit is connected to the robot control
- Cleaning device is connected to the robot control

Only if present/used

- If present, the parting agent nebuliser is started up
- If using the dipping bowl, the dipping bowl is filled with the "Robacta TC Cool / Robacta TC Cool MD" parting agent
- Connect the 'Robacta Reamer' parting agent container to the cleaning unit
- Wire cutter installed and supplied with compressed air

Welding torch cleaning position when using Robacta TC 1000 TwinCompact

For best coating of the welding torch interior with parting agent during cleaning, feed the Twin welding torch into the cleaning opening as shown:

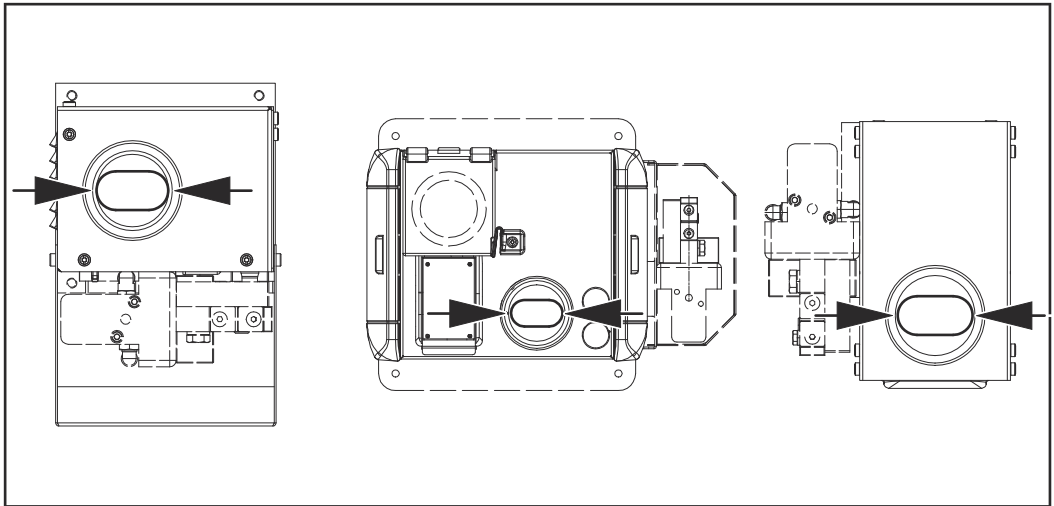

NOTE!

Ensure that the gas nozzle does not touch the housing components of the cleaning opening at any time.

Cleaning programme

Overview of program sequence with dipping bowl

1. Welding
2. Cooling torch in dipping bowl
3. Cleaning gas nozzle tip
4. Welding
5. Cooling torch in dipping bowl
6. Cleaning the nozzle fitting
7. Welding

Overview of program sequence with parting agent nebuliser

1. Welding
2. Cleaning gas nozzle tip
3. Spraying in parting agent
4. Welding
5. Cleaning the nozzle fitting
6. Spraying in parting agent
7. Welding

Overview of program sequence with parting agent nebuliser and dipping bowl

1. Welding
2. Cooling torch in dipping bowl
3. Cleaning gas nozzle tip
4. Spraying in parting agent
5. Welding
6. Cooling torch in dipping bowl
7. Cleaning the nozzle fitting
8. Spraying in parting agent
9. Welding

Cooling welding torch in the dipping bowl - detailed description

Immersing the hot welding torch in the "Robacta TC Cool / Robacta TC Cool MD" parting agent has the following benefits:

- The spatter that has accumulated on the gas nozzle is loosened
- The welding torch is cooled down more
- The anti-adhesive agent in the "Robacta TC Cool / Robacta TC Cool MD" parting agent prevents renewed soiling

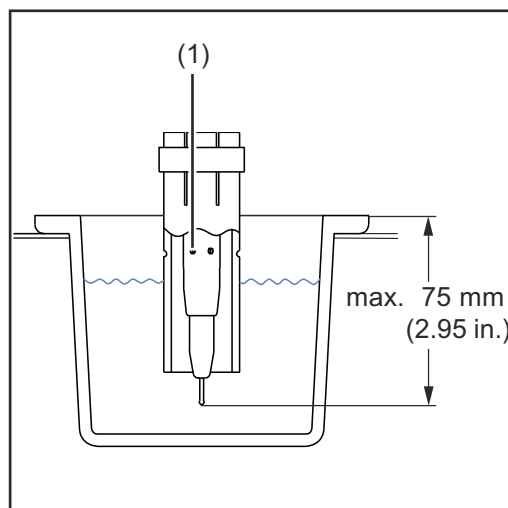

- 1 After welding, position the welding torch approximately 50 mm (1.97 in.) above the dipping bowl

NOTE!

Do not dip the welding torch more than 75 mm (2.95 in.) into the dipping bowl. The gas holes (1) must remain dry.

- 2 Dip the welding torch vertically into the dipping bowl

- 3 Depending on the application, hold the welding torch in the dipping bowl for approximately 1 - 4 seconds so that any air in the torch can escape and the torch can cool sufficiently
- 4 Raise the welding torch back to its original position above the dipping bowl
- 5 Allow the welding torch to drip for approximately 1 - 4 seconds or blow down it with compressed air using the hosepack before bringing it back to its original position for cleaning

Cleaning the gas nozzle tip - detailed description

NOTE!

During the cleaning operation, blow out the welding torch with compressed air through the hosepack - any remaining dirt or parting agent is removed.

NOTE!

Ensure that the gas nozzle does not touch the housing components of the cleaning opening at any time.

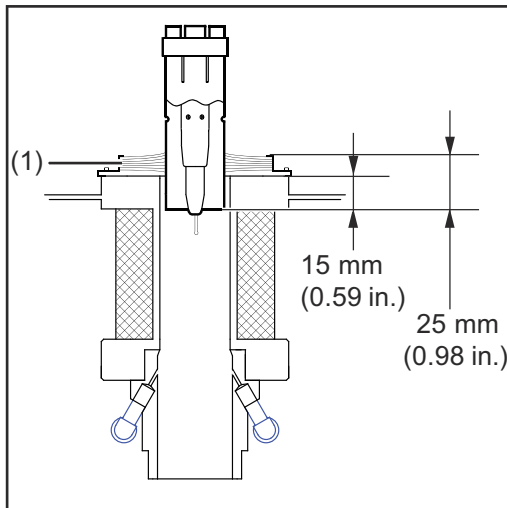

- 1 Position the welding torch approx. 40 mm (1.57 in.) centrally above the middle of the cleaning opening

NOTE!

If the brush seal (1) is not fitted, note the changed reference point when positioning the welding torch.

- 2 Insert welding torch vertically into cleaning opening.
 - The optimum immersion depth for the tip of the gas nozzle is 25 mm (0.98 in.)
- 3 Begin cleaning and hold the welding torch in the cleaning position for approximately 1 second

Cleaning the nozzle fitting - detailed description

NOTE!

During the cleaning operation, blow out the welding torch with compressed air through the hosepack - any remaining dirt or parting agent is removed.

NOTE!

Ensure that the gas nozzle does not touch the housing components of the cleaning opening at any time.

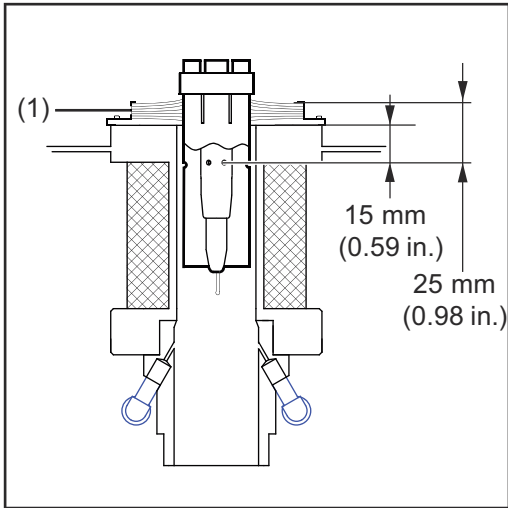

- 1 Position the welding torch approx. 40 mm (1.57 in.) centrally above the middle of the cleaning opening

NOTE!

If the brush seal (1) is not fitted, note the changed reference point when positioning the welding torch.

- 2 Insert welding torch vertically into cleaning opening. Immerse the torch so that the gas nozzle holes are approx. 25 mm (0.98 in.) inside the cleaning opening

- 3 Begin cleaning and hold the welding torch in the cleaning position for approximately 1 second

Spraying parting agent - detailed description

Applying parting agent evenly has the following advantages:

- shorter cleaning time
- prevents re-soiling

NOTE!

Ensure that the gas nozzle does not touch the housing components of the cleaning opening at any time.

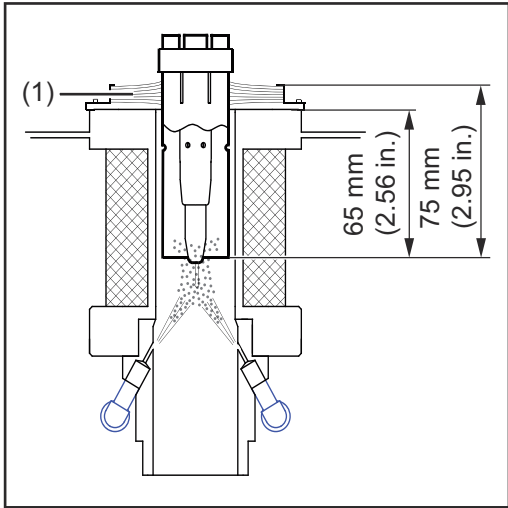

NOTE!

If the brush seal (1) is not fitted, note the changed reference point when positioning the welding torch.

- 1 Place the welding torch in the spray position
 - see figure

NOTE!

During the spraying process, ensure that compressed air is not blown out through the welding torch.

- 2 Spray welding torch with parting agent for approximately 0.7 seconds
- 3 Move the welding torch to the start position above the cleaning opening - approx. 40 mm (1.57 in.) centrally above the middle of the cleaning opening
 - The cleaning operation is complete and the welding torch is ready for use again

- 4 Ensure that not too much parting agent has accumulated on the gas nozzle (no droplet formation). If this is the case:
- Reduce the spray time or
 - After the cleaning operation, blow out the welding torch with compressed air using the hosepack

Cleaning program sequence with dipping bowl

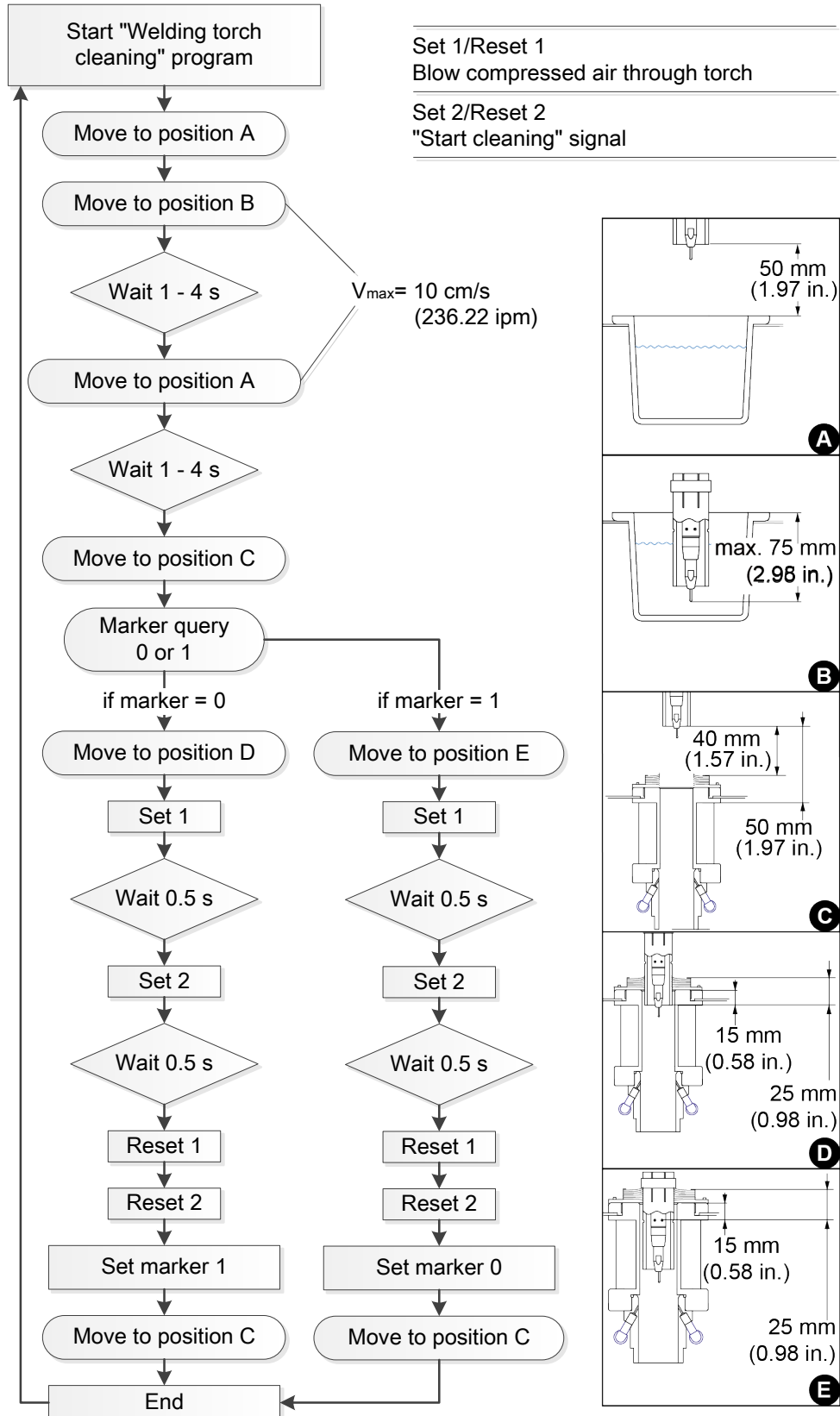

Cleaning program sequence with parting agent nebuliser

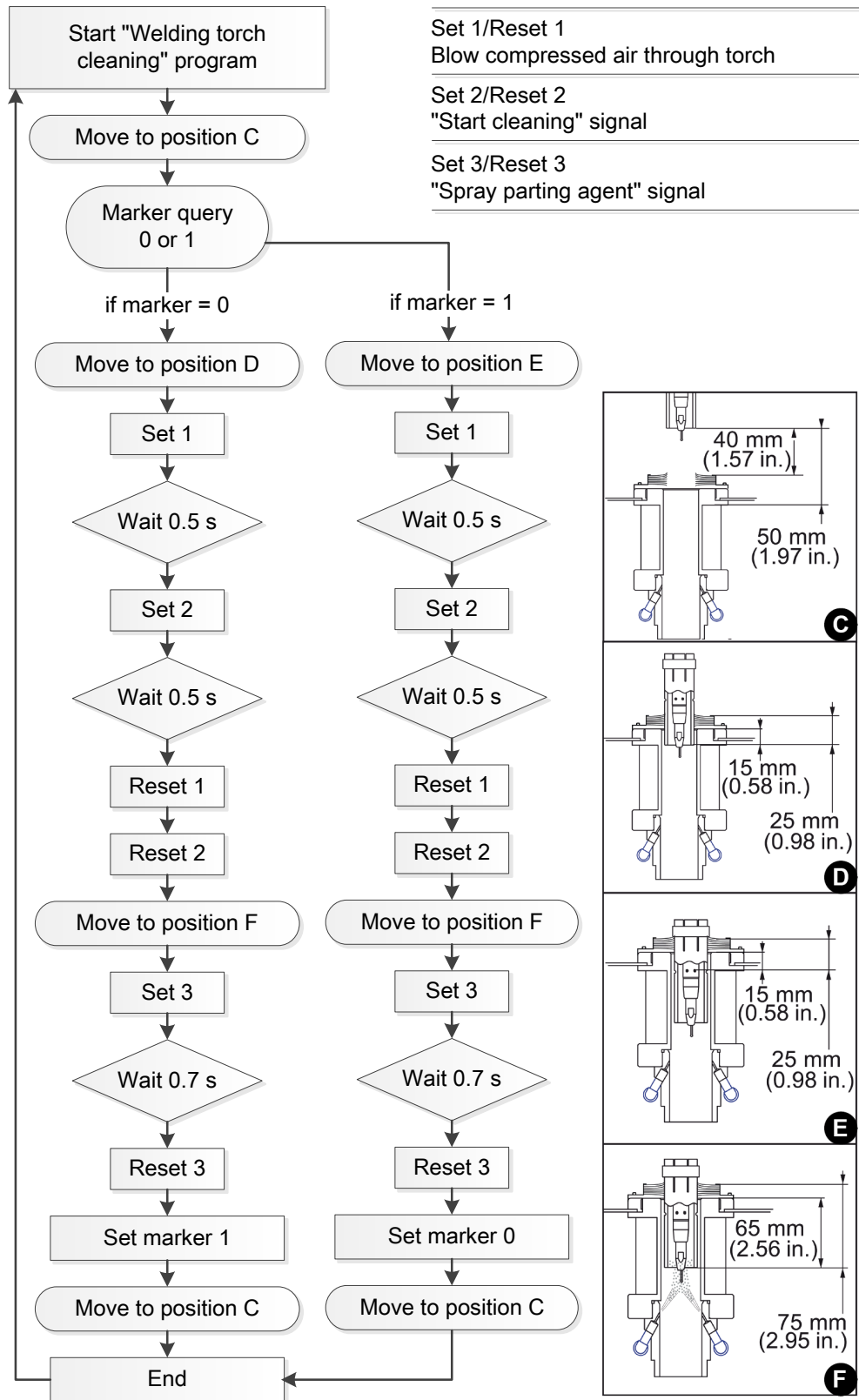

Troubleshooting, maintenance and disposal

Safety

Observe the following safety rules for all work described in the "Troubleshooting, maintenance and disposal" section.

WARNING!

Danger from incorrect operation and work that is not carried out properly.

This can result in serious personal injury and damage to property.

- ▶ All the work and functions described in this document must only be carried out by a trained Fronius service technician.
- ▶ Read and understand this document in full.
- ▶ Read and understand all safety rules and user documentation for this device and all system components.

WARNING!

Risk of machines starting automatically.

This can result in serious personal injury and damage to property.

- ▶ In addition to these Operating Instructions, also observe the safety rules issued by the manufacturer of the robot and welding system.
- ▶ Ensure that all protective measures have been taken and will remain in place while you are in the working area of the robot.

WARNING!

Danger from electric current and mechanically powered parts.

This can result in serious personal injury and damage to property.

- ▶ Before working on the cleaning device or the associated system components, disconnect the customer's compressed air and power supply from the cleaning device and the associated system components.
- ▶ Ensure that they remain disconnected until all work is complete.

WARNING!

**Whenever the cleaning device is supplied with voltage and/or compressed air, a risk of serious injury exists from:
the magnetic field of the cleaning opening
flying parts (shavings, etc.)
compressed air/parting agent mixture escaping from the cleaning opening
activated wire cutter**

This can result in serious personal injury and damage to property.

If work has to be performed on the cleaning device while it is being supplied with voltage and/or compressed air, take the following protective measures:

- ▶ Keep all ferromagnetic parts away from the device (e.g. tools).
- ▶ Keep your body, especially your hands, face and hair, any objects and all clothing away from the cleaning opening and the wire cutter.
- ▶ Wear ear protection.
- ▶ Wear protective goggles with side protection.



WARNING!

Danger from inadequate ground conductor connection.

This can result in serious personal injury and damage to property.

- ▶ The housing screws provide a suitable ground conductor connection for earthing the housing and must NOT be replaced by any other screws which do not provide a reliable ground conductor connection.
-

Troubleshooting

Mains voltage indicator not lit

Mains cable connected

Cause: Faulty mains cable

Remedy: Check mains cable

Ready-to-clean signal not transmitted to robot control

Mains voltage indicator lit

Cause: Quick Stop is active (HI - Quick Stop = LO / LO - Quick Stop = HI)

Remedy: Deactivate Quick Stop (HI - Quick Stop = HI / LO - Quick Stop = LO)

Cause: Supply to I/O standard connection socket (X1) is faulty

Remedy: Check assignment of inputs A, B and H

Ready-to-clean signal not transmitted to robot control

Mains voltage indicator lit, overtemperature indicator lit

Cause: The cleaning device is overheating

Remedy: Allow cleaning device to cool down. Once the permitted operating temperature has been reached, charging of the capacitors starts again. The cleaning device is then ready to clean again

Fill level indicator lit

The liquid in the dipping bowl is below the optimum fill level

Cause: "Robacta TC Cool / Robacta TC Cool MD" parting agent container is empty

Remedy: Replace "Robacta TC Cool / Robacta TC Cool MD" parting agent container

Fill level indicator lit

The "Robacta TC Cool / Robacta TC Cool MD" parting agent container is not yet empty

Cause: Level sensor is dirty

Remedy: Clean level sensor with fresh water

Cause: Level sensor faulty

Remedy: Contact After-Sales Service

Fill level indicator not lit

The liquid in the dipping bowl is already below the optimum fill level

Cause: Fill-level sensor faulty

Remedy: Contact After-Sales Service

The parting agent does not spray

Parting agent container is full

Cause: Not enough spray

Remedy: Adjust spray amount (spray time)

Cause: Dirty suction filter in "Robacta Reamer" parting agent container

Remedy: Blow through suction filter in parting agent container 'Robacta Reamer' using compressed air from the inside outwards through the suction hose (see [Starting up the parting agent nebuliser V](#) on page 54)

Cause: Compressed air is not being supplied

Remedy: Establish a compressed air supply

Cause: Compressed air supply line faulty or dirty

Remedy: Clean compressed air supply line, replace if necessary

Cause: Vacuum pump faulty (parting agent nebuliser V)

Remedy: Contact After-Sales Service (arrange for vacuum pump to be replaced)

Cause: Faulty solenoid valve

Remedy: Contact After-Sales Service (arrange for solenoid valve to be replaced)

The parting agent does not spray

Cause: The "Robacta Reamer" parting agent container is empty

Remedy: Fill with parting agent

Cause: Interconnecting hosepack damaged (only on Robacta TC 1000 ext.)

Remedy: Contact After-Sales Service

Pores in the weld seam

Cause: Too much parting agent inside the welding torch

Remedy: Remove parting agent residue by blowing out the torch interior. Ensure supply of compressed air

Cause: Too much parting agent inside the welding torch

Remedy: Reduce amount of parting agent spray (shorten duty cycle of pump for parting agent)

Error is sent to the robot, no cleaning takes place

Cause: The required magnetic field could not be established when discharging the capacitors via the cleaning coil.

Remedy: Leave the torch in the cleaning position. Wait for the ready-to-clean signal and carry out a new cleaning operation.

If the cleaning operation error occurs three times in succession, contact After-Sales Service.

Error is sent to the robot. Overtemperature and fill level indicators flash at the same time, no cleaning takes place

Cause: Quick Stop is active (HI - Quick Stop = LO / LO - Quick Stop = HI)

Remedy: Deactivate Quick Stop (HI - Quick Stop = HI / LO - Quick Stop = LO)

Cause: Fault in the cleaning device

Remedy: Disconnect the cleaning device from the mains and wait for approx. 1 minute before reconnecting it to the mains

Contact After-Sales Service if this does not remedy the situation

Fault procedure for Robacta TC 1000 ext.

Fault procedure

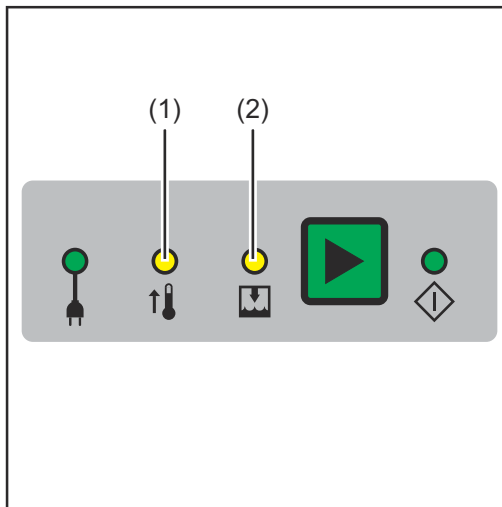

WARNING!

Risk of serious injury and material damage from electric shocks.

The cleaning device has a serious fault if

- ▶ the overtemperature (1) and fill level (2) indicators are flashing at the same time
- ▶ the Quick-Stop signal is not active

If this is the case, the interconnecting hosepack may only be disconnected from the base unit once the following safety measures have been met.

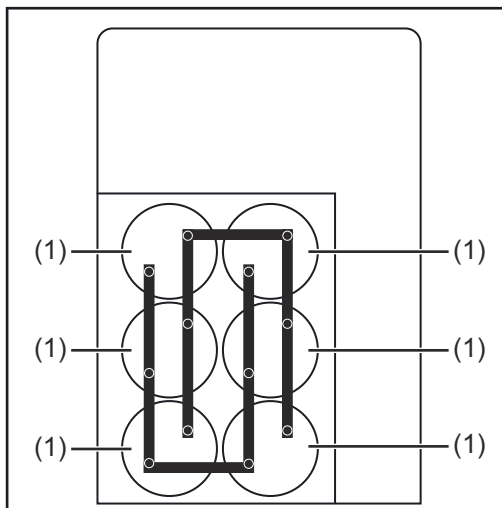

Side view of the base unit with open side panel

Safety measures:

- 1** Ensure that the base unit has been disconnected from the power supply
- 2** Ensure that the cleaning unit has been disconnected from the compressed air supply
- 3** Remove the left side panel from the base unit (as seen from the front)
- 4** Ensure that all 6 capacitors (1) have been fully discharged
- 5** Refit the side panel
 - The cleaning unit interconnecting hosepack may now be disconnected from the cleaning unit

Care, maintenance and disposal

Before each start-up

- 1 Check the fill level in the "Robacta Reamer" parting agent nebuliser/parting agent container and the dipping bowl, top up if necessary

NOTE!

The "Robacta TC Cool / Robacta TC Cool MD" and "Robacta Reamer" parting agents differ in their composition.

Use the appropriate medium depending on the application concerned.

Daily

NOTE!

Only use solvent-free cleaning products on the devices.

- 1 Remove any deposits of parting agent or contaminants from the outside of the base and cleaning units.

Weekly

Robacta TC 1000:

- 1 Empty the spatter tray for welding residues
- 2 Take the spill tray out of the dipping bowl and dispose of any accumulated dirt
- 3 Check the consistency of the "Robacta TC Cool / Robacta TC Cool MD" parting agent. If the "Robacta TC Cool / Robacta TC Cool MD" parting agent is viscous, add fresh water and stir to mix with the parting agent
- 4 Check the level sensor in the dipping bowl for dirt and clean if necessary
- 5 Clean the cleaning opening on the inside
- 6 Check the "Robacta TC Cool / Robacta TC Cool MD" parting agent container and the "Robacta Reamer" parting agent container for soiling and clean if necessary
- 7 Blow through suction filter in parting agent container 'Robacta Reamer' using compressed air from the inside outwards through the suction hose (see [Starting up the parting agent nebuliser V](#) on page 54)
- 8 Check the condition of the brush seal above the cleaning opening. Replace the brush seal if worn

Robacta TC 1000 ext.:

- 1 Empty the spatter tray for welding residues on the cleaning unit S.
- 2 Clean the inside of the cleaning unit cleaning opening
- 3 Check the parting agent container 'Robacta Reamer' for contaminants and clean if necessary
- 4 Blow through suction filter in parting agent container 'Robacta Reamer' using compressed air from the inside outwards through the suction hose (see [Starting up the parting agent nebuliser V](#) on page 54)
- 5 Check the condition of the brush seal above the cleaning opening. Replace the brush seal if worn

Every 3 months

NOTE!

Take care never to damage the level sensor when performing maintenance work.

Robacta TC 1000:

- 1 Drain all the parting agent from the dipping bowl
- 2 Take the spill tray out of the dipping bowl and dispose of any accumulated dirt
- 3 Clean the dipping bowl and spill tray
- 4 Fill the dipping bowl with new parting agent

Every 6 months

NOTE!

Do not bring the air nozzle too close to electronic parts.

- 1 Robacta TC 1000 / Robacta TC 1000 ext. Open (base unit and cleaning unit) and blow clean using dry reduced compressed air

Every 12 months

- 1 Arrange for a safety inspection to be carried out on the cleaning device by a Fronius service engineer

Clean suction filter in parting agent container

NOTE!

Only use "Robacta Reamer" parting agent supplied by the manufacturer.

The composition of the manufacturer's parting agent is intended specifically for the Robacta TC. If other manufacturers' products are used, trouble-free operation cannot be guaranteed.

1 litre container:

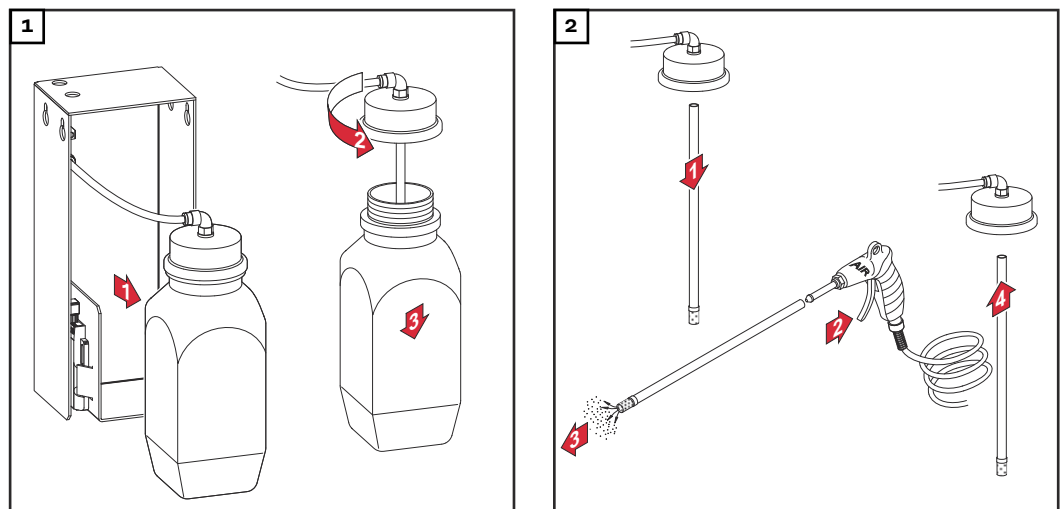

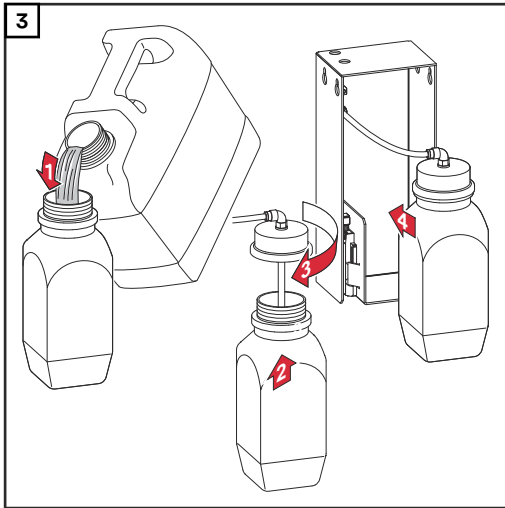

10 litre container:

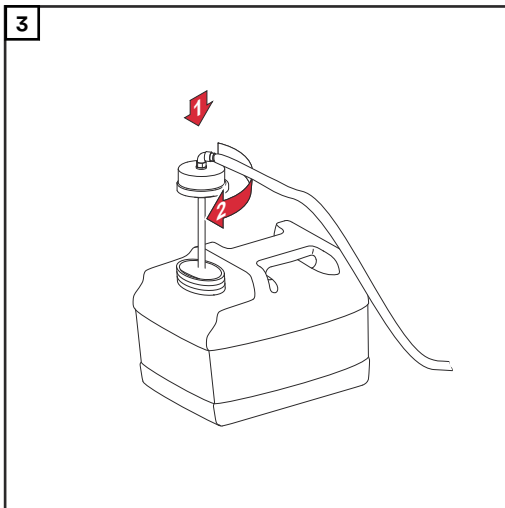
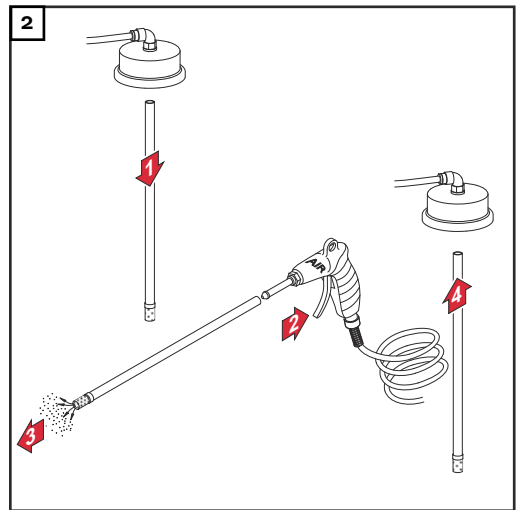
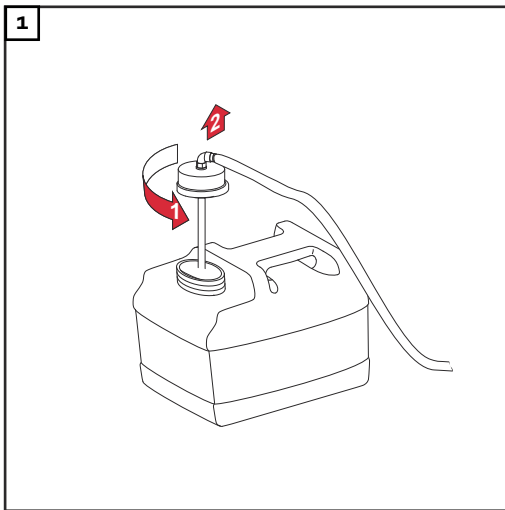

Disposal

Dispose of in accordance with the applicable national and local regulations.

Technical data

Technical data

General



CAUTION!

Danger due to insufficiently dimensioned electrical installations.

This can result in severe damage to property.

- ▶ Dimension the mains lead and its fuse to suit the device being used. The technical data shown on the rating plate applies.

Robacta TC 1000 / Robacta TC 1000 ext. (Base unit) / Robacta TC 1000 Twin / Robacta TC 1000 Twin Compact

	Robacta TC 1000 / Twin / Twin Compact	Robacta TC 1000 ext. (Base unit)
Mains voltage	230 V	230 V
Mains voltage tolerance	-15% / +15%	-15% / +15%
Grid frequency	50/60 Hz	50/60 Hz
Nominal output	180 W	180 W
Mains fuse protection (slow-blow)	10 A	10 A
Compressed air supply	6 bar 86.99 psi	- -
Minimum cleaning interval	45 s	45 s
Discharge current	Approx. 1500 A	Approx. 1500 A
Discharge voltage	270 V DC	270 V DC
Dipping bowl minimum capacity	0.75 l 0.20 gal.	- -
Degree of protection	IP 21	IP 21
Dimensions l/w/h	330 / 250 / 422 mm 12.99 / 9.84 / 16.61 in.	330 / 250 / 422 mm 12.99 / 9.84 / 16.61 in.
Weight (without "dip-in" parting agent)	13 kg 28.66 lbs.	11.5 kg 25.35 lb.
EMC device class	A	A
Marks of conformity	CE, CSA	CE, CSA

Cleaning unit S/P

	Cleaning unit S	Cleaning unit P
EMC emission class	A	A
Compressed air supply	6 bar 86.99 psi	6 bar 86.99 psi
Dimensions l/w/h	212 / 121 / 119 mm 8.35 / 4.76 / 4.69 in.	365 / 202 / 300 14.37 / 7.95 / 11.81 in.

	Cleaning unit S	Cleaning unit P
Weight (without "dip-in" parting agent)	6 kg 13.23 Ib.	8 kg 17.64 lb.

NOTE!

Cleaning units S and P are also available for Twin and Twin Compact torch shapes.

Robot control supply

	Condition	Minimum	Typical	Maximum
Supply voltage	Continuous operation	15 V _{DC}	24 V _{DC}	24 V _{DC}
Current input	Supply voltage = 24 V	-	30 mA	100 mA
Standby current input	Supply voltage = 24 V	25 mA	30 mA	40 mA

Digital inputs

		No voltage (LO)	High active (HI)
U _O	Input not in use, no current input	18 V _{DC}	0 V _{DC}
U _{On}	Starting threshold	< 10 V _{DC}	> 15 V _{DC}
U _{Off}	Switch off threshold	> 20 V _{DC}	< 2 V _{DC}
U _{Hy} st	Hysteresis	10 V	13 V
I _{On}	Input current during start	6.8 mA at 15 V	670 uA at 15 V
C _{In-} put	Input capacity	47 nF	47 nF
U _{Inv}	Incorrectly connected input voltage	60 V _{DC} (max)	60 V _{DC} (max)
U _{Ma} x	Input overvoltage protection	100 V _{DC} / 42 V _{DC} (max.)	100 V _{DC} / 42 V _{DC} (max.)
U _{Mi} n	Filter time	> 100 ms	> 100 ms

Digital outputs

		Minimum	Typical	Maximum
U _O	Voltage	-	24 V _{DC}	30 V _{DC}
I _{Shift}	Switching current	0 A	-	20 mA
I _{SC}	Short circuit current (stable)	-	30 mA	-

		Minimum	Typical	Maximum
U_{Max}	Overvoltage protection	-	-	$60 V_{DC} / 60 V_{DC}$
U_{Invers}	Incorrectly connected output voltage	-	-	$60 V_{DC}$
R_{Open}	Input resistance for open output	100 kOhm	-	-
R_{on}	Input resistance for active output	8 Ohm	10 Ohm	12 Ohm
U_{On}	Residual input voltage	-	-	$1 V_{DC}$
C_{output}	Output capacitance	-	47 nF	-
dU / dT	Voltage fluctuation during switching	-	$0.5 V_{DC} / \mu s$	-



Fronius International GmbH

Froniusstraße 1
4643 Pettenbach
Austria
contact@fronius.com
www.fronius.com

At www.fronius.com/contact you will find the contact details
of all Fronius subsidiaries and Sales & Service Partners.